

NDM5-160 Molded case circuit breaker

Scope of application

- > The NDM5-160 series of molded case circuit breakers (MCCBs) with the rated insulation voltage of 800V are applicable to the AC 50Hz or 60Hz circuits with the rated operating voltage of AC230V, AC400V and AC690V, and the rated operating current of 16A~160A for electrical energy distribution, as well as protection of circuits and power supply devices in case of overload, short circuit, undervoltage (With the UVT);, the products are also used to protect motors during infrequent starting, braking, overload, short circuit, etc..
- > The isolating function with the relative symbol: 
- > Standards: IEC60947-2 and GB14048.2.

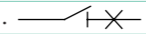

Model and implication

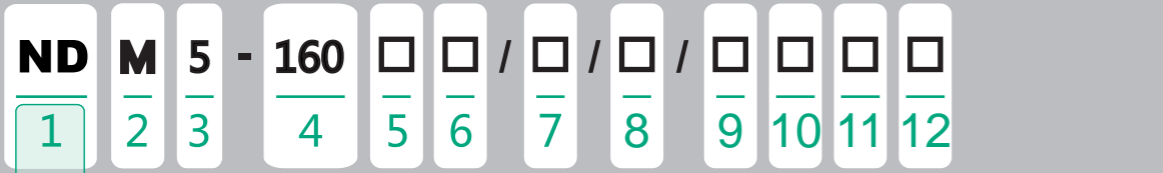







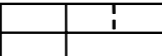
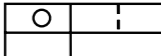
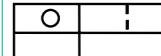
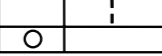
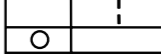
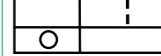
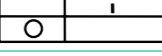
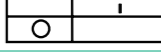
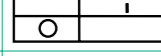
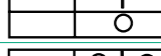
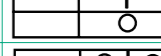
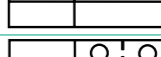
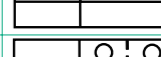
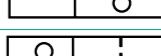
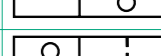

No.	Implication	Model
1	Enterprise code "NADER"	ND
2	Molded case circuit breaker	N
3	Design code	5
4	Frame current Inm (A):	160
5	Breaking level code:	S, H, L
6	Rated current In (A):	16, 20, 25, 32, 40, 50, 63, 80, 100, 125, 160
7	Number of poles	(Refer to "Note a")
8	Release code	(Refer to "Note b")
9	Installation modes	(Refer to "Note c")
10	Connection modes	(Refer to "Note d")
11	Operating modes	(Refer to "Note e")
12	Accessories	(Refer to "Table 1")

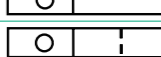
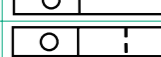
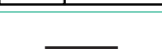
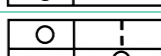
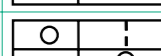
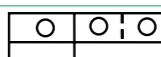
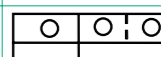
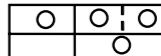
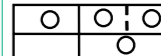
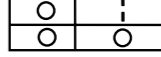
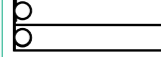
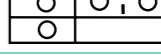
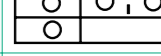
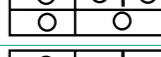
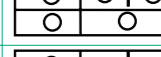
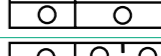
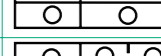
Note:

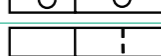
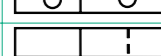
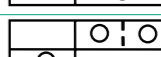
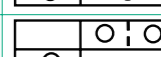
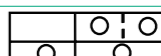
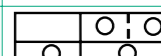
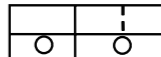
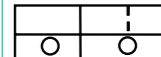
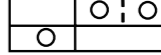
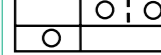
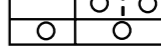
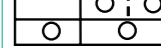
- a) Number of poles
 > 2: 2 poles; 3: 3 poles; 4: 4 poles;
 > 4A: There is no overcurrent protection on Pole N, and Pole N is always on;
 > 4B: There is no overcurrent protection on Pole N, and Pole N opens and closes with the other three poles (Pole N closes at first, and opens at last);
 > 4C: There is overcurrent protection on Pole N, and Pole N opens with the other three poles (Pole N closes at first, and opens at last);
 > 4D: There is overcurrent protection on Pole N, and Pole N is always on.
- b) Release code
 TMD (Distribution protection): [Thermal adjustable (0.8-0.9-1.0) In, magnetic adjustable (5-6-7-8-9-10) In, for power distribution];
 TMM (Motor protection): [Thermal adjustable (0.8-0.9-1.0) In, magnetic adjustable (8-9-10-11-12-13-14) In, for motors];
 Note: The magnetic adjustment scope of TMM (Motor protection) is (10-11-12-13-14) In.
- c) Installation modes: Fixed: "No code" ; plug-in: "P" ; guide rail: "G" .
- d) Connection modes: Front wiring: "No code" ; front extension wiring: "ES" ; front bare copper cable wiring: "FCu" ; rear screw wiring: "R" .
- e) Operating modes: Direct handle operation: "No code" ; rotary handle operation: "R" ; motor operation: "M" (Note: Not applicable to 2P).

Table 1

Accessory code	Name of accessory	Mounting position		
		2P	3P	4P
00	No	—	—	—
10	Alarm contact			
20	Shunt release			
30	Undervoltage release			
40	Single auxiliary contact	—		
50	Double auxiliary contacts	—		
60	Three auxiliary contacts	—		
12	Alarm contact + shunt release			
13	Alarm contact + undervoltage release			
14	Alarm contact + single auxiliary contact	—		
15	Alarm contact + double auxiliary contacts	—		
16	Alarm contact + three auxiliary contacts	—		
70	Alarm contact + shunt release + single auxiliary contact	—		
71	Alarm contact + shunt release + double auxiliary contacts	—		
72	Alarm contact + shunt release + three auxiliary contacts	—		
80	Alarm contact + undervoltage release + single auxiliary contact	—		
81	Alarm contact + undervoltage release + double auxiliary contacts	—		
82	Alarm contact + undervoltage release + three auxiliary contacts	—		
24	Shunt release + single auxiliary contact	—		
25	Shunt release + double auxiliary contacts	—		
26	Shunt release + three auxiliary contacts	—		
34	Undervoltage release + single auxiliary contact	—		
35	Undervoltage release + double auxiliary contacts	—		
36	Undervoltage release + three auxiliary contacts	—		

Main technical parameters

Table 2

Frame current Inm (A)		160								
Rated current In (A)		16, 20, 32, 40, 50, 63, 80, 100, 125, 160 ;								
Rated voltage Ue (V)		AC230, AC400 (Not applicable to 2P) , AC690 (Not applicable to 2P)								
Rated impulse withstand voltage Uimp (1s)		8kV								
Rated insulation voltage Ui (V)		800								
Power frequency withstand voltage (1min)		3000V								
Rated ultimate breaking capacity Icu(kA)	Code	S			H			L		
	AC230V (2P, 3P, 4P)	100			120			150		
	AC400V (3P, 4P)	70			100			150		
Rated operating breaking capacity Ics(kA)	AC690V (3P, 4P)	8			12			15		
	Ics=100%Icu									
Life	Mechanical life	25000times								
	Electrical life	AC230V, AC400V			18000times					
AC690V			8000times							
Wiring capacity	Current(A)	16, 20	25	32	40, 50	63	80	100	125	160
	Sectional area (mm ²)	2.5	4	6	10	16	25	35	50	70

Normal operating environment

- > a) Elevation: ≤2000m.
- > b) Ambient temperature: -25°C~+70°C.
- > c) Class of pollution: 3.
- > d) Endure moist air, salt fog and oil fog.
- > e) Max. gradient: 22.5°.
- > f) In the medium without explosion hazard, and the medium contains no gas and conductive dust that may corrode metal and damage insulation.
- > g) In a place without snow and rain influence.

Tripping characteristics (Refer to Fig. 1 and 2)

> Tripping characteristic curve in normal environment (The ambient temperature is 40°C), refer to Fig. 1 and 2.

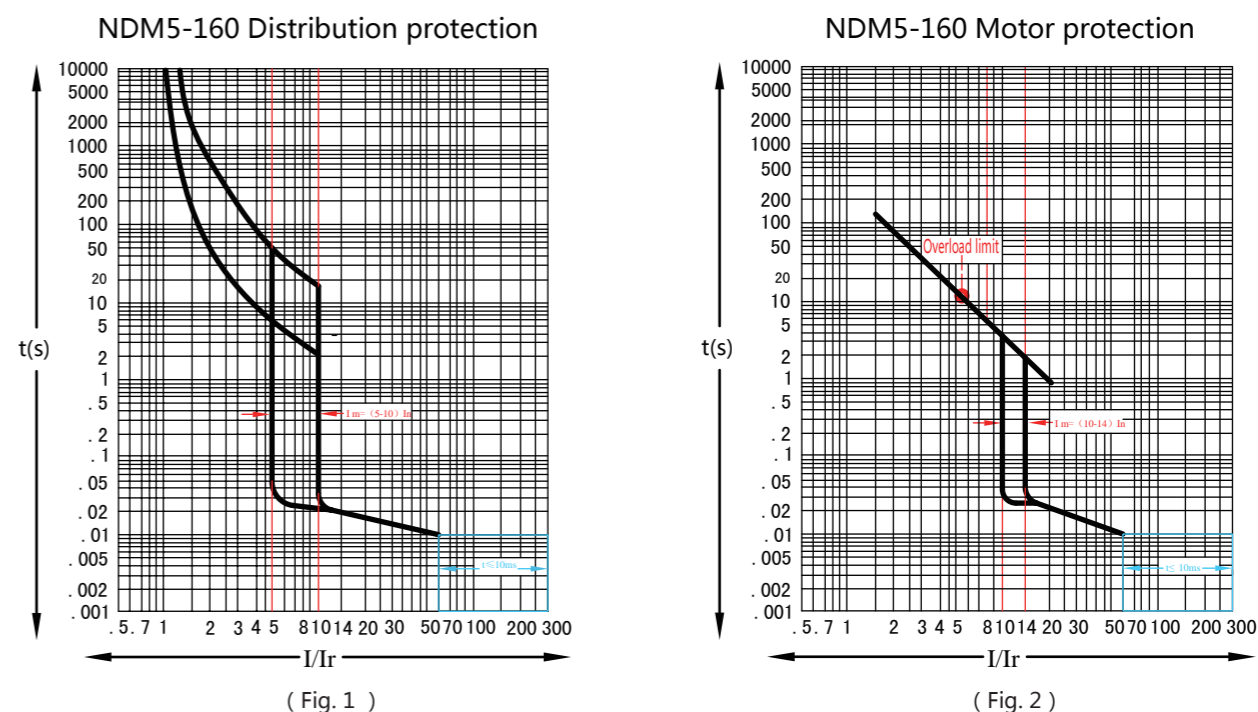

Table 3

> If ambient temperature fluctuates, there will be small change in tripping characteristics, which shall be corrected (Refer to Table 3)

Ambient air temperature	Coefficient for temperature correction
-25°C	1.33
-20°C	1.305
-15°C	1.278
-10°C	1.251
-5°C	1.225
0°C	1.2
5°C	1.175
10°C	1.15
15°C	1.125
20°C	1.1
25°C	1.075
30°C	1.05
35°C	1.025
40°C	1.0
45°C	0.975
50°C	0.95
55°C	0.925
60°C	0.9
65°C	0.875
70°C	0.85

Table 4

> When the elevation is more than 2000m at the ambient temperature +40°C, in consideration of insulation characteristic and cooling capacity of air, there will be change in tripping characteristics, which shall be corrected (Refer to Table 4)

Elevation (m)	2000	3000	4000	5000
Power frequency withstand voltage (V)	3000	2700	2400	2100
Average insulation class (V)	1Ui	0.9Ui	0.8Ui	0.7Ui
Max. operating voltage (V)	1Ue	0.9Ue	0.8Ue	0.7Ue
Average operating current (+40°C)	1In	0.96In	0.93In	0.9In

Power consumption and internal resistance (Refer to Table 5)

Table 5

Rated current(A)	Fixed type			
	Internal resistance of each phase (mΩ)			Total power consumption on three poles (W)
	A	B	C	
16	8.86	9.03	8.59	6.77
20	7.21	7.55	7.33	8.83
25	4.26	4.26	4.31	8.01
32	3.14	2.95	2.89	9.19
40	2.54	2.48	2.78	12.48
50	2.23	2.23	2.32	16.95
63	2.05	2.14	2.12	25.04
80	0.97	1.1	0.86	18.75
100	0.57	0.57	0.77	19.1
125	0.57	0.57	0.77	29.84
160	0.37	0.47	0.44	32.76

Internal accessories

Table 6

> Parameters and description of auxiliary contacts (Refer to Table 6)

Accessory	Voltage (V)/Conventional thermal current (Ith)		
Auxiliary contact	AC250V/10A	AC400V/3A	DC220V/0.2A

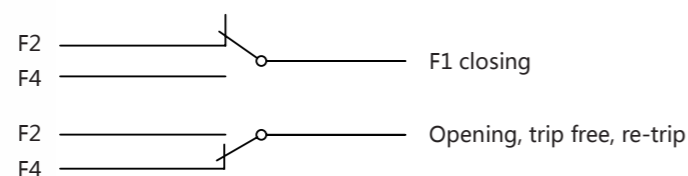

Parameters and description of alarm contact (Refer to Table 7)

Table 7

Accessory	Voltage (V)/Conventional thermal current (Ith)	
Alarm contact	AC250V/10A	DC220V/0.2A

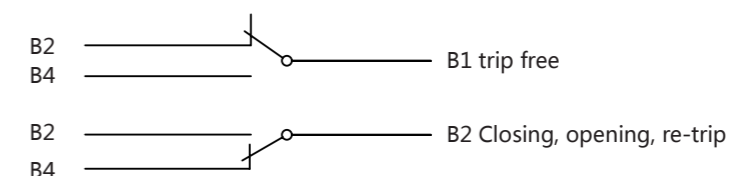

Undervoltage release (Refer to Table 8)

Table 8

> When the supply voltage drops to 35%~70% of rated operating voltage of the undervoltage release, the release can break the circuit breaker reliably; when the supply voltage is less than 35% of the rated operating voltage of the undervoltage release, the release can prevent the circuit breaker from closing; and when the supply voltage is more than 85% of the rated operating voltage of the undervoltage release, the release can guarantee reliable closing of the circuit breaker.

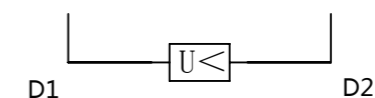

Accessory	Rated operating voltage		
Undervoltage release	AC110V/DC110V	AC230V/DC250V	AC400V

Shunt release (Refer to Table 9)

Table 9

> The shunt release can break the circuit breaker reliably when the applied voltage is between 70%~110% of the rated control supply voltage.

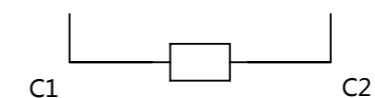

Accessory	Rated control voltage			
Shunt release	AC24V/DC24	AC48V/DC48	AC110V/DC110V	AC230V/DC250V

Connection capacity (Refer to Table 10)

Table 10

Rated current (A)	16, 20	25	32	40, 50	63	80	100	125	160
Sectional area of Conductor (mm ²)	2.5	4	6	10	16	25	35	50	70

Overall and mounting dimension

Overall dimension

Front connection (Refer to Fig. 5)

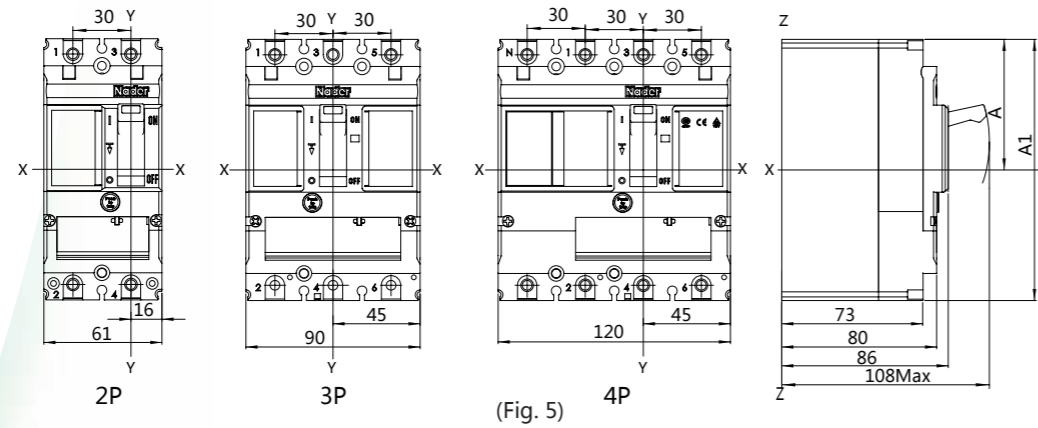

Note: The dimension of front connection without accessories: A=67.5, A1=135;
The dimension of front bare copper cable connection with accessories: A=77.5, A1=155.

Overall dimension of front extension connection (Refer to Fig. 6)

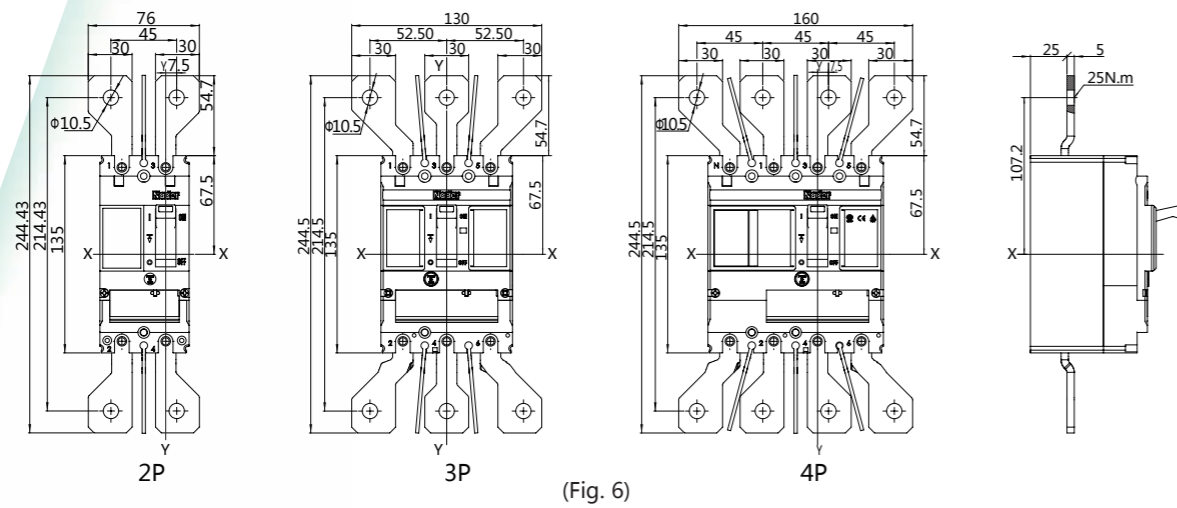

Mounting dimension

Mounting on the baseplate (Refer to Fig. 7)

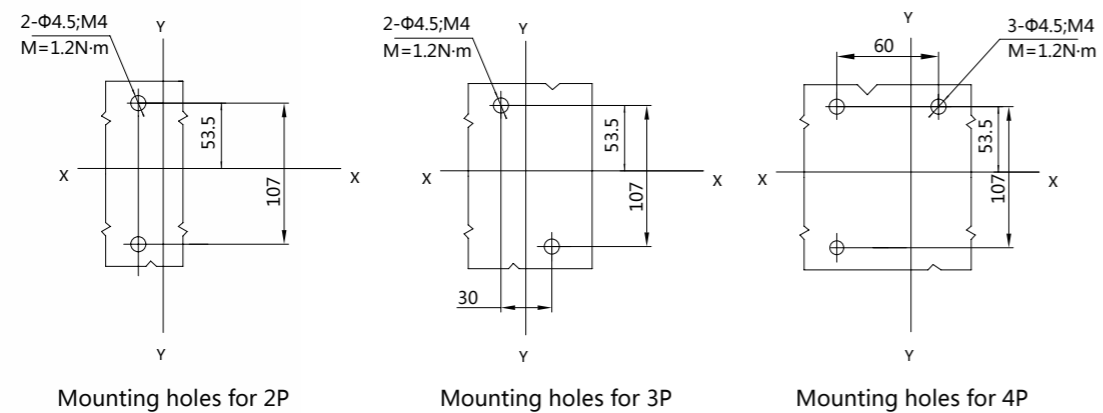

(Fig. 7)

Mounting on the DIN guide rail with the adapter (Refer to Fig. 8)

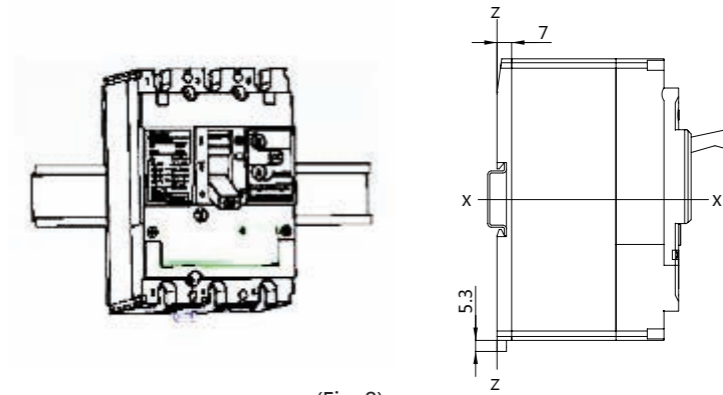

(Fig. 8)

Mounting modes (Refer to Fig. 9)

Both horizontally or vertically

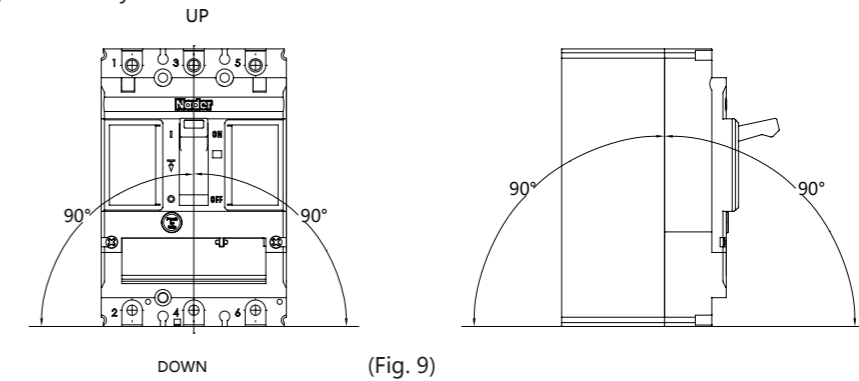

(Fig. 9)

Package and storage

- > The Min. packing quantity is 1 pc/box, the products packed in box shall be stored in the warehouse where the ambient temperature is 5°C~35°C, the RH is under 80%, and ambient air does not contain any acid, alkaline or other corrosive gas. The storage period under the above mentioned conditions shall be no more than 18 months since the date of production.
- > Storage temperature: -40°C~+70°C.

Accessories and installation

Table 11

No.	Name	Specification	Qty./pc		
			2P	3P	4P
1	Cress recessed small pan head screw	M4×75	2	2	3
2	Flat washer	4	2	2	3
3	Spring washer	4	2	2	3
4	Hexagon nut	M4	2	2	3
5	Interphase insulating barrier	—	2	4	6

Notice

- > a) The performance parameters here are for normal conditions. Any special requirements shall be confirmed officially before readjustment and putting into operation;
- > b) Only the trained or qualified professionals can mount and maintain this circuit breaker, the tripping unit or other accessories;
- > c) Before mounting or dismantling any device, make sure that the power supply has been cut off.