

NDB1LE-63 Product Specification

Product Name: Residual Current Action Circuit Breaker

Product Model: NDB1LE-63

Date: 20181030

Prepared by Chen Bo Date 10/30/2018

Reviewed by Huo Zhiqiang Date 10/30/2018

Approved by Duan Hui Date 10/30/2018

Revision History

Version	Revision Reason/Content	Implementation Date	Prepared by	Reviewed by	Approved by
0	New addition	20151029	Ye Wenjie Ling Yi	Dong Min	Duan Hui
1	Update the company's logo and modify the rated current	20160622	Ling Yi	Dong Min	Duan Hui
2	Update the product picture and modify the maximum packaging quantity	20160707	Ling Yi	Dong Min	Duan Hui
3	Change outline and installation dimensions	20160805	Ling Yi	Ye Wenjie	Duan Hui
4	Modify the rated impulse withstand voltage	20161114	Ling Yi	Ye Wenjie	Duan Hui
5	Add the assembled accessory information	20181030	Chen Bo	Huo Zhiqiang	Duan Hui

1. Application Scope and Purpose

- Short-circuit protection
- Overload protection
- Current leakage
- Isolation

The NDB1LE-63 series of residual current action circuit breakers provide the ground leakage, direct or indirect electric shock by human body and other faults protection, which are applicable to the low-voltage terminal distribution in the industry, civil buildings, energy, communication, infrastructure and other fields.

2. Picture of the Product

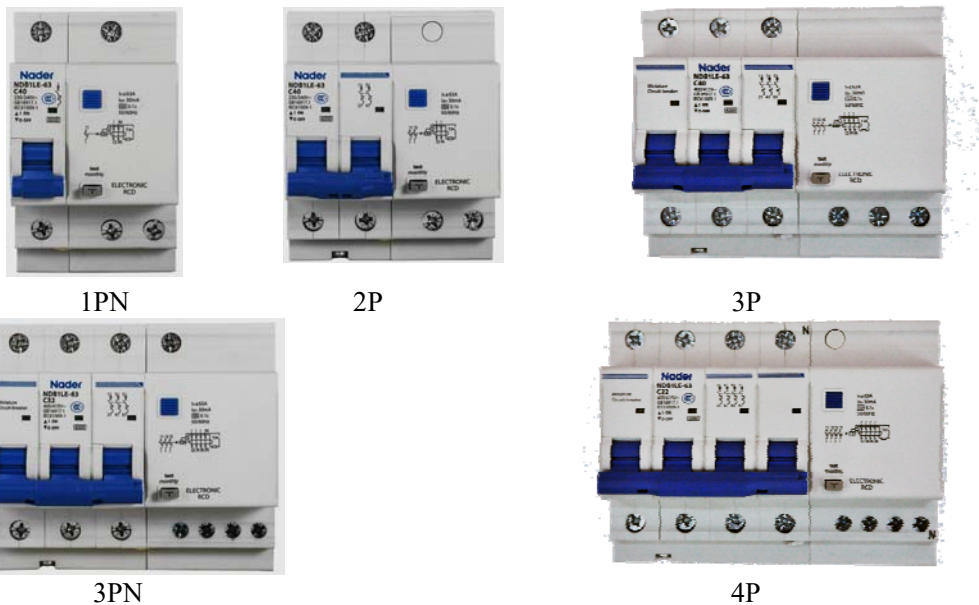

3. Specifications and Models Description

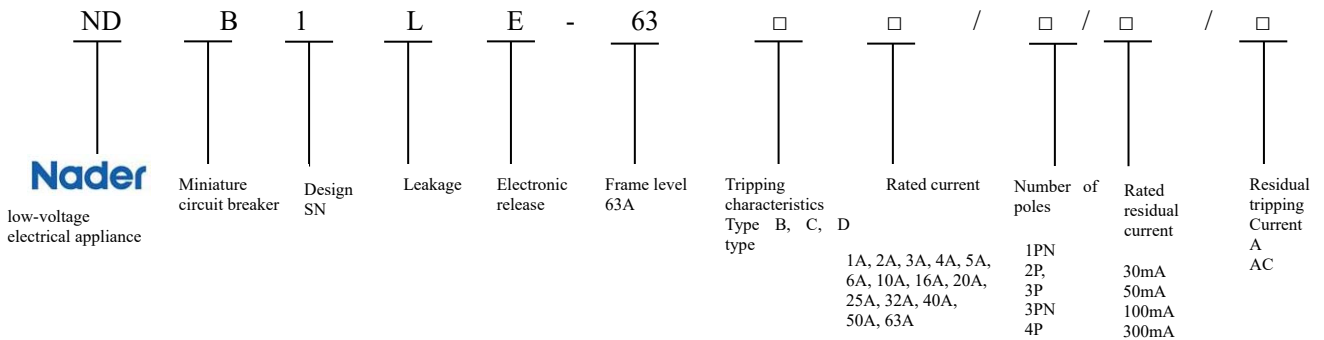

4. Main Technical Parameters

- Electrical parameters

- Frequency: 50/60Hz
- Rated working voltage: AC230V/240V (1PN, 2P), AC400V/415V (3P, 3PN, 4P)
- Rated impulse withstand voltage: 6kV
- Rated insulation voltage: 500V
- Type of the residual tripping current: Type A, Type AC
- Instantaneous tripping characteristics: Type B, C, D
- Rated working current: 1A, 2A, 3A, 4A, 5A, 6A, 10A, 16A, 20A, 25A, 32A, 40A, 50A, 63A
- Rated breaking capacity: 6kA
- Rated residual operating current: 30mA, 50mA, 100mA, 300mA
- Mechanical life: 20,000 times
- Electrical life: 10,000 times

- Isolating function

- Leakage visualization

- Wiring

- Tunnel terminal blocks
- Terminal connection area: Apply to (1~10mm²) conductor (1~32A); apply to (10~25mm²) conductor

(40~63A)

- Standard torque: 1.2N.m (1~32A); 2.0N.m (40~63A)

- Protection class

- Protection class of the circuit breaker body: IP20
- To be installed in the distribution box: IP40

5. Normal Working Environment

- Altitude: $\leq 2000\text{m}$, In case of use at the higher altitude, refer to the requirements of the miniature circuit breaker for derating. Refer to GB/T20645 “Specific Environmental Condition - Technical Requirements of Low-voltage Apparatuses for Plateau”.

- Pollution level: 3

- Ambient temperature: $-25^{\circ}\text{C}\sim+60^{\circ}\text{C}$

- Wet heat resistance: Capable of withstanding the effects of wet air (the humidity is 90%-96% at 55°C ; the humidity is 95%-100% at 25°C)

- Storage ambient temperature: $-40^{\circ}\text{C}\sim+80^{\circ}\text{C}$

- The product can withstand the effects of salt mist and oil mist

- The product can be disposed in places that are free from explosive media, media corrosive to metal,

insulation damaging gas, and conductive dust

- The product should be installed free from snow and rain

6. Tripping Characteristics

• Type B curve

- Protect the non-inductive or micro-inductive circuit
- Rated current: 1A~63A
- Tripping characteristics: Range of instantaneous tripping $3I_n \sim 5I_n$

• Type C curve

- Protect the conventional load and distribution cable
- Rated current: 1A~63A
- Tripping characteristics: Range of instantaneous tripping $5I_n \sim 10I_n$

• Type D curve

- Protect the industrial power distribution system
- Rated current: 1A~63A
- Tripping characteristics: Range of instantaneous tripping $10I_n \sim 14I_n$

Type B (3~5) I_n

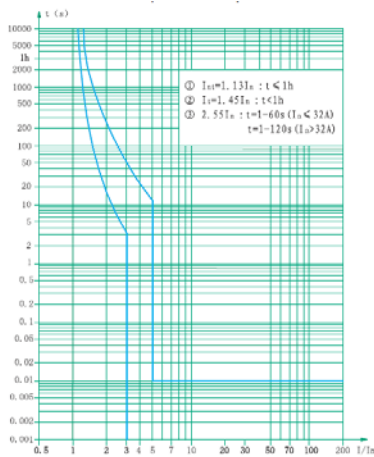

Type C (5~10) I_n

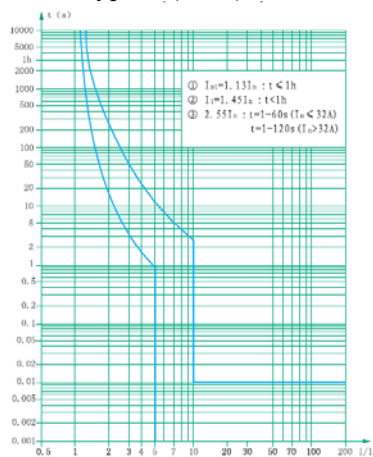

Type D (10~14) I_n

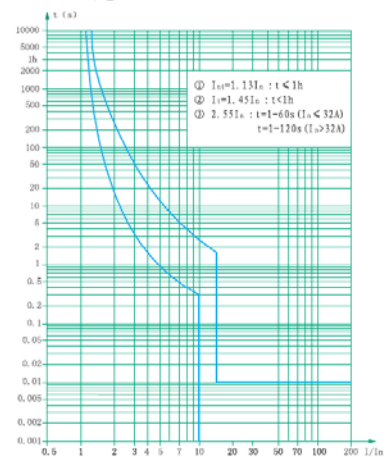

7. Product Outline and Installation Dimensions

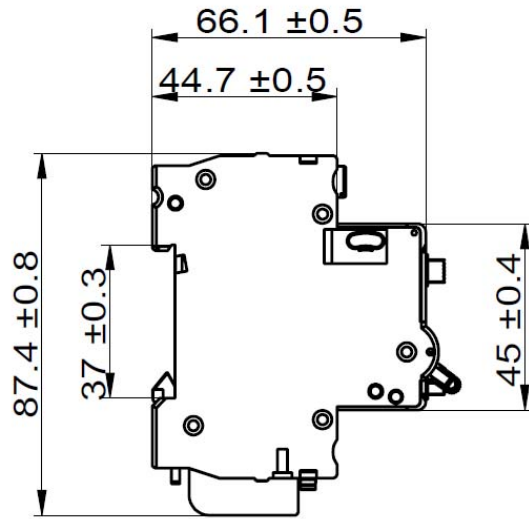
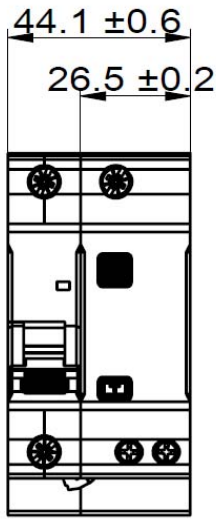

1~32A-1PN

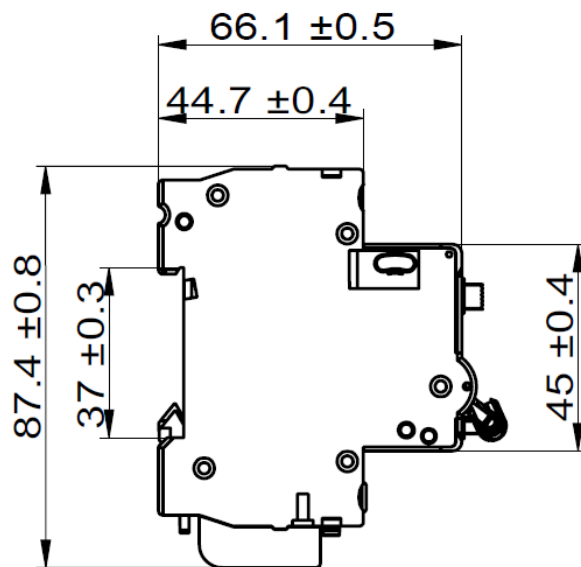
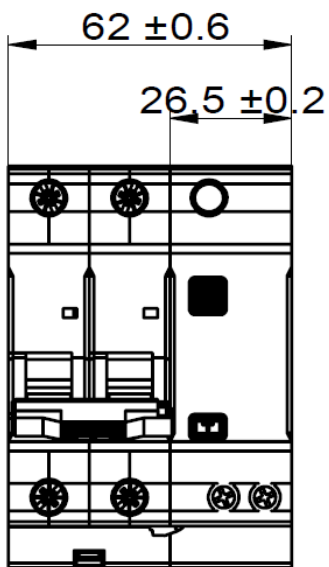

1~32A-2P

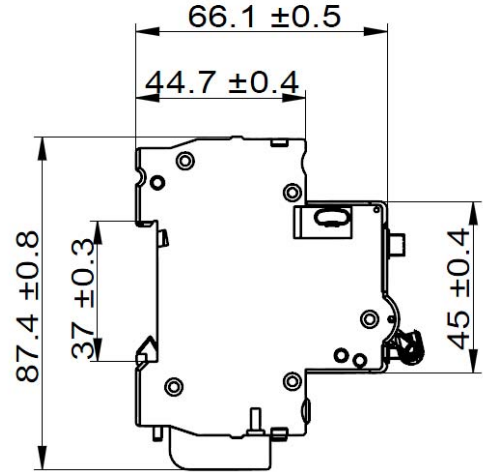
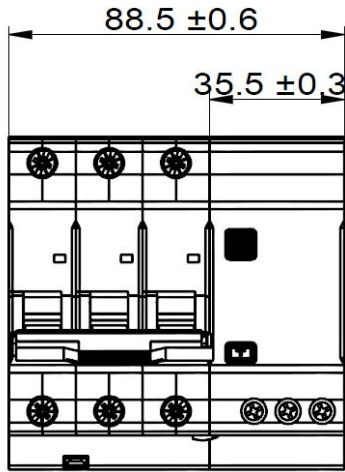

1~32A-3P

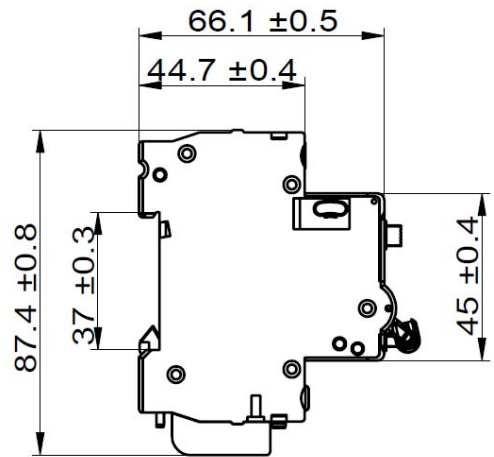
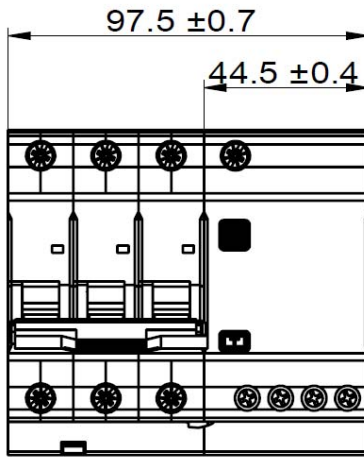

1~32A-3PN

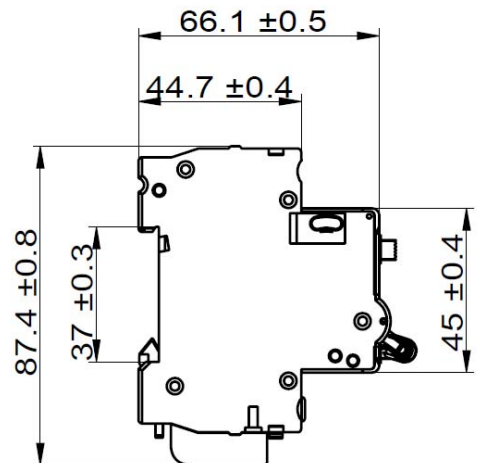
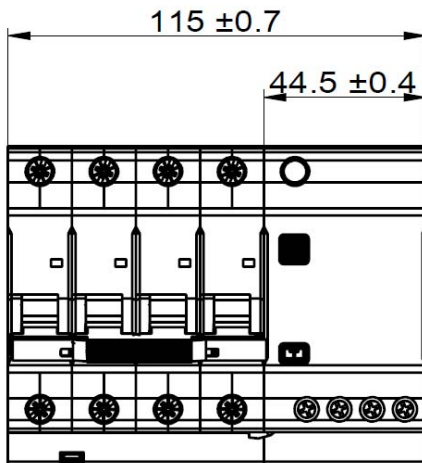

1~32A-4P

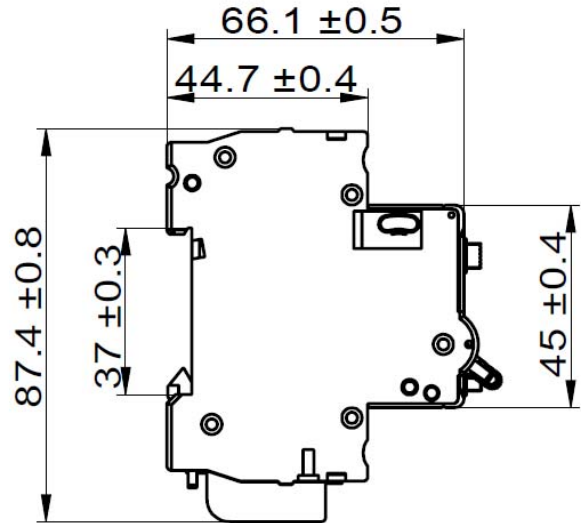
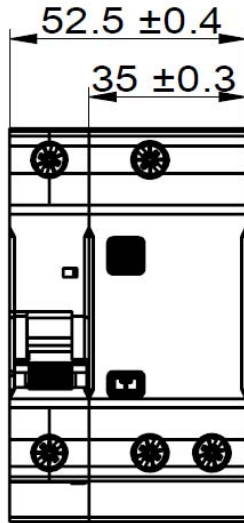

40~63A-1PN

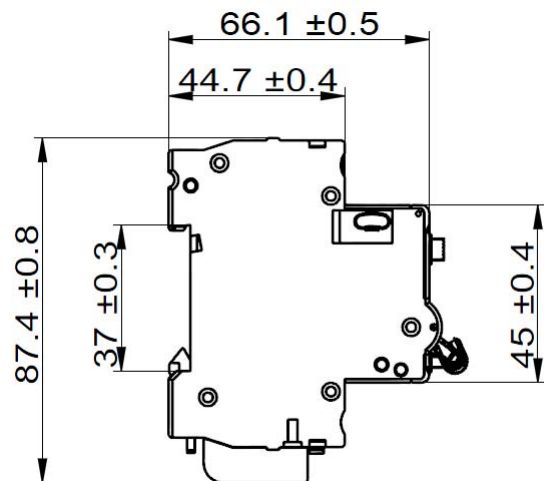
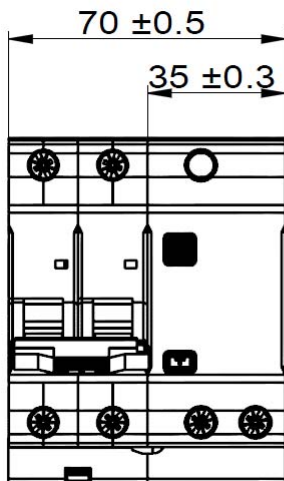

40~63A-2P

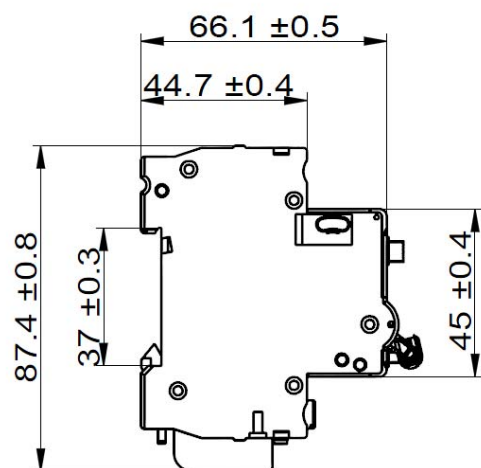
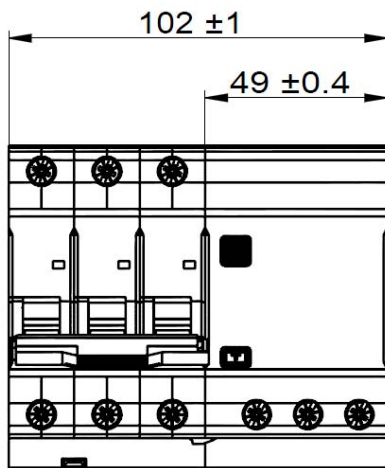

40~63A-3P

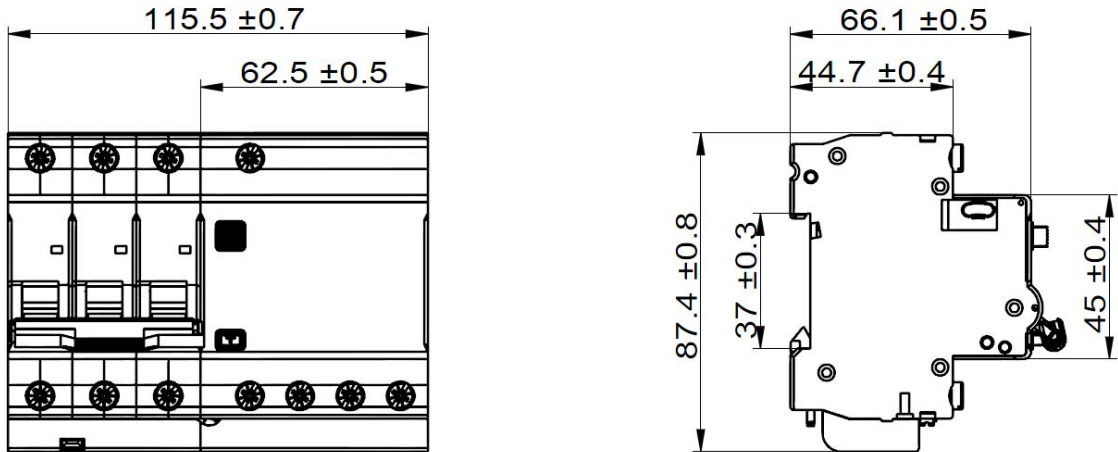

40~63A-3PN

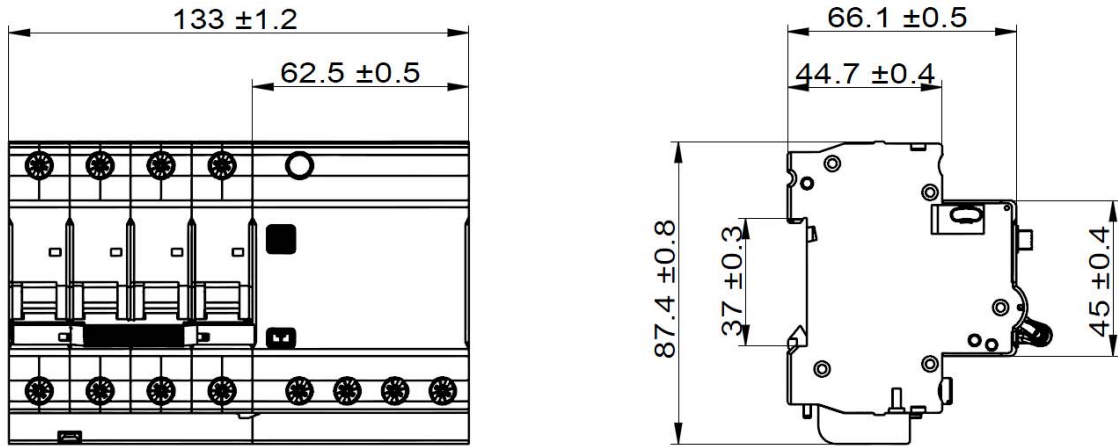

40~63A-4P

8. Installation Mode

It can be easily installed on the TH35mm×7.5 standard guide

9. Packaging and Storage

Maximum packaging quantity: (1PN product: 5 pieces/box, 2P product: 4 pieces/box, 3P product: 2 pieces/box, 3PN/4P product: 1 piece/box). The packaged products should be stored in a warehouse with the air ventilation and the relative humidity no more than 80% and the temperature between -40°C and +80°C. No acidic, alkaline or other corrosive gas exists in the ambient air in the warehouse. Under the above conditions, the storage period shall be no more than three years since the manufacturing date.

10. List of Accessories and Installation

- OF1 auxiliary contact Install on the left side of the miniature circuit breaker for indicating the on-off state of the circuit breaker;
- SD1 alarm contact Install on the left side of the miniature circuit breaker for indicating the fault tripping state of the circuit breaker.
- MX+OF1 shunt release Install on the left side of the miniature circuit breaker for the remote control of the circuit breaker tripping.
- GQ1A under-voltage/over-voltage release Install on the left side of the miniature circuit breaker for protection in case of under-voltage and over-voltage.

11. Environmental Protection Requirements

Comply with the requirements of RoHS directives.

12. Precautions

- A user must be responsible for addressing a product issue that occurs because the user disassembles the product without approval;
 - It fails to provide protection for the electric shock caused due to two phases of the contacted lines to be protected;
 - Do not test the insulation resistance of the product or carry out power frequency withstand voltage tests directly or indirectly with a megger or similar devices on the product so as to avoid damage to the product. If required by users, our company can provide an effective proof of the conformance test;
 - In case of insulation resistance test on the project line, do not connect the product so as to avoid misunderstanding of the product quality or damage to the circuit board;
 - Wiring of the leakage circuit breaker shall be done according to the up-in and down-out principle. Do not wire it wrongly. Otherwise, it may damage the product by pressing the test button again or in case of current leakage in the line;
 - Wiring must be reliable to prevent the malfunction of the leakage circuit breaker or terminal burning damage due to the abnormal heat generation on the terminal;
 - Carry out a monthly stimulated test on the current leakage. Namely, press the test button to make the circuit breaker act so as to test proper operation of the circuit breaker, and replace the abnormal products in a timely manner;
 - For automatic disconnection of the leakage circuit breaker, analyze fault reasons for the line or equipment.
-