

Product Datasheet

Product Name: Circuit Breaker for Equipment

Models : NDB3-100

Date : 20181030

Made	Checked	Approved
Kang Fan	Zhang Jian	Duan Hui

	File name	Product Datasheet	File number	NDT500489
	Product name	NDB3-100 series circuit breaker for equipment	Version	The 3 th version
			Date	20181030

Revision Records

Version	Revised contents and reasons	Date	By (full name)
2	Change description of "application"	20170512	Zhang Jian
3	Unified updated version according to the requirements of company	20181030	Kang Fan

File number	NDT500044	Version	The 3 th version	Date	20181030
-------------	-----------	---------	-----------------------------	------	----------

1 Application

NDB3-100 series circuit breaker for equipment (hydraulic-magnetic circuit breaker) is used in the power system with rated current from 0.5A to 400A, rated voltage up to AC250V、AC400/415V (50/60Hz) or DC125V. It provides overload, short circuit protection. It can also be used for infrequent close or open. The application fields are computer and peripheral equipment, industrial automatic control system, telecom equipment, power supply system, UPS, railroad, marine, spacecraft, elevator, portable power supply and so on.

2 Model and Implication

N D B 3 - 100 XX X / X X X XX X X - X
 1 2 3 4 5 6 7 8 9 10 11 12 13
XXXXX

14

No.	Implication	NDB3-100	
1	Brand code	ND "Nader" brand	
2	Product code	B Circuit Breaker for Equipment	
3	Design code	3	
4	Frame size	100	
5	Tripping curve	Z2 DC short delay Z4 DC medium delay Z6 DC long delay	J2 AC short delay J4 AC medium delay J6 AC long delay
6	Rated current (A)	Standard CBE Parallel Connected CBE (DC only)	1, 2, 3, 4, 5, 6, 8, 10, 12, 15, 16, 20, 24, 25, 30, 32, 35, 36, 40, 45, 50, 60, 70, 80, 90, 100 B + rated current: Paralleled (3P, 4P) F + rated current: Paralleled, wiring separately (2P, 3P, 4P) P + rated current: Paralleled w/o connection bar (2P, 3P, 4P) Rated current: 2P: 100A, 125A, 150A, 160A, 175A, 200A; 3P: 175A, 200A, 225A, 250A, 275A, 300A; 4P: 275A, 300A, 325A, 350A, 375A, 400A.
7	Number of poles	1 One pole 2 Two poles 3 Three poles (Please refer to 3.9 "Rated breaking capacity" for current choosing) 4 Four poles ($\geq 275A$, DC only, actuator code S*/L* available)	
8	Mounting method	L M3 screw mounting M 6-32UNC screw mounting	

File number	NDT500044	Version	The 3 th version	Date	20181030
-------------	-----------	---------	-----------------------------	------	----------

9	Wiring method	<p>S: M6 bolt-in wiring, double nuts</p> <p>U: M6 bolt-in wiring, single nut</p> <p>T: M5 bolt-in wiring, double nuts (non-UL489≤50A, UL489≤30A)</p> <p>V: M5 bolt-in wiring, single nut (non-UL489≤50A, UL489≤30A)</p> <p>L: M5 screw wiring (non-UL489≤50A, UL489≤30A)</p> <p>C: Push-in stud wiring (non-UL489≤100A, UL489≤50A)</p> <p>B: Plug-in stud wiring (non-UL489≤100A, UL489≤50A)</p> <p>H: 1/4-20 UNC bolt-in wiring, double nuts</p> <p>N: 1/4-20 UNC bolt-in wiring, single nut</p> <p>P: 10-32 UNF bolt-in wiring, double nuts (non-UL489≤50A, UL489≤30A)</p> <p>W: 10-32 UNF bolt-in wiring, single nut (non-UL489≤50A, UL489≤30A)</p> <p>K: 10-32 UNF screw wiring (non-UL489≤50A, UL489≤30A)</p>
10	Actuator code	<p>S1: Black long handle, white legend, ON/OFF, with current rating</p> <p>S2: Black long handle, white legend, ON/OFF, I/O, with current rating</p> <p>S3: White long handle, black legend, ON/OFF, with current rating</p> <p>S4: White long handle, black legend, ON/OFF, I/O, with current rating</p> <p>S5: Yellow long handle, black legend, ON/OFF, with current rating</p> <p>S6: Yellow long handle, black legend, ON/OFF, I/O, with current rating</p> <p>Y1: Black rocker, vertical white legend, ON/OFF, I/O, with current rating</p> <p>Y2: Black rocker, horizontal white legend, ON/OFF, I/O, with current rating</p> <p>Y3: Black rocker, vertical white legend, ON/OFF, I/O</p> <p>Y4: Black rocker, horizontal white legend, ON/OFF, I/O</p> <p>Y5: Black rocker, vertical white legend, ON/OFF, I/O, with current rating, indication ON</p> <p>Y6: Black rocker, horizontal white legend, ON/OFF, I/O, with current rating, indication ON</p> <p>Y7: Black rocker, vertical white legend, ON/OFF, I/O, with current rating, indication OFF</p> <p>Y8: Black rocker, horizontal white legend, ON/OFF, I/O, with current rating, indication OFF</p> <p>A1: Black flat rocker, vertical white legend, ON/OFF, I/O, with current rating, white indication OFF, handle position "OFF" with guard</p> <p>A2: Black flat rocker, vertical white legend, ON/OFF, I/O, with current rating, white indication OFF</p> <p>A4: Black flat rocker, horizontal white legend, ON/OFF, I/O, with current rating, white indication OFF</p> <p>L1: Black long handle, white legend, ON/OFF</p> <p>L2: Black long handle, white legend, ON/OFF, I/O</p> <p>L3: White long handle, black legend, ON/OFF</p> <p>L4: White long handle, black legend, ON/OFF, I/O</p> <p>L5: Yellow long handle, black legend, ON/OFF</p> <p>L6: Yellow long handle, black legend, ON/OFF, I/O</p>
11	Actuator number	<p>A One per pole</p> <p>B One per multi-pole (for multi-pole products only)</p>
12	Accessory code	<p>0 No accessory</p> <p>1 With auxiliary contact (in the left side as viewed from front of breaker)</p>

File number	NDT500044	Version	The 3 th version	Date	20181030
-------------	-----------	---------	-----------------------------	------	----------

13	Certificate code	No code CCC, TUV, CE R CCC, TUV, CE, UL1077 L CCC, TUV, CE, UL489A (for DC products only) K CCC, TUV, CE, UL489 (AC:1A~70A, DC:1~100A) C CCC, TUV, CE, UL1077, KC (for wiring method S/T products only)
14	Customer code	Customer code (Additional option)

Notes: 1.

Current (A)	1~100		>10	
Actuator code	S	S/Y/A	L	L/Y/A
Wiring method	S/T/C/U/V/B/L/H/P/NW/K	U/V/B/L/NW/K	S/U/H/N	U/N
Number of poles	1,2,3	1,2,3	2,3,4	2,3
Actuator number	A	B	A	B

2. For special requirements beyond this form, please contact our sales offices.

Note: Illustration of the actuator type

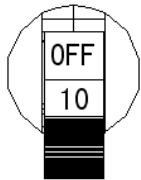

S1/S3/S5

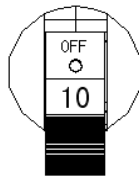

S2/S4/S6

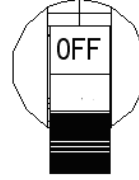

L1/L3/L5

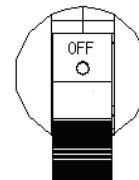

L2/L4/L6

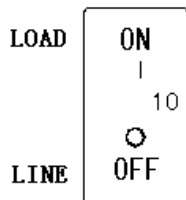

Y1 (Single color)

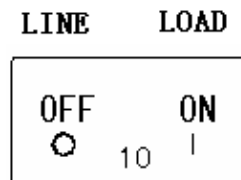

Y2 (Single color)

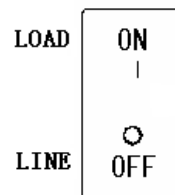

Y3 (Single color)

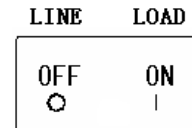

Y4 (Single color)

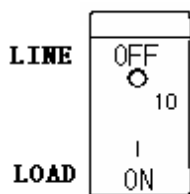

Y5
(Dual colors, indicate "ON")

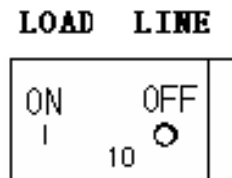

Y6

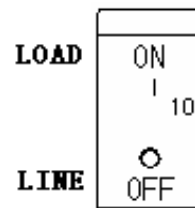

Y7
(Dual colors, indicate "OFF")

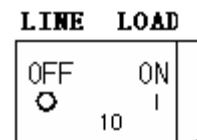

Y8

File number	NDT500044	Version	The 3 th version	Date	20181030
-------------	-----------	---------	-----------------------------	------	----------

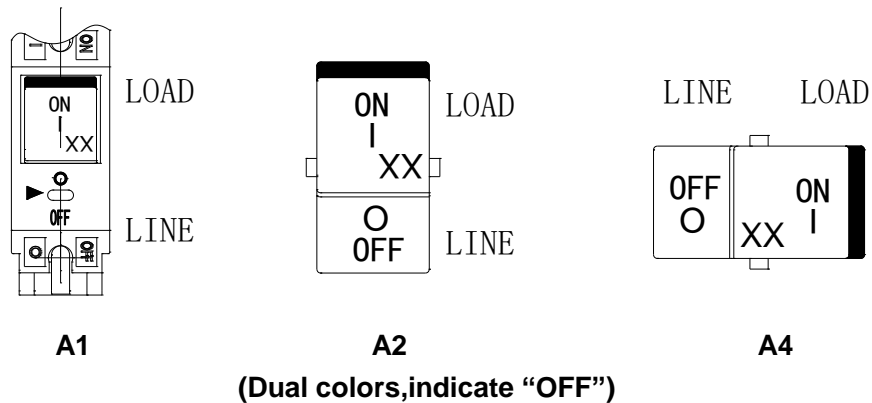

3 Specification

- 3.1 Standards: GB/T 17701, GB/T 14048.2, IEC/EN60934, IEC/EN60947-2, UL1077, UL489A, UL489
- 3.2 Rated working voltage (Ue): DC80V, DC125V, AC230/240V, AC250V, AC400/415V
- 3.3 Mechanical/Electrical endurance: 10000/6000 times
- 3.4 Power frequency withstand voltage: 3000V(Main circuit), 1000V(Auxiliary circuit)
- 3.5 Approvals: CCC, CE, TUV, UL1077, UL489A, UL489, KC, CRCC
- 3.6 Parameter for auxiliary contact/mid trip alarm contact: AC250V 5A
- 3.7 Rated breaking capacity

Mode	Voltage (V)	Rated current (A)	Number of poles	Breaking capacity (A)							
				CCC		UL489A	UL1077	UL489	TUV/CE		Korea KC
				GB/T 17701	GB/T 14048.2				EN60934	EN60947-2	
NDB3-100	DC80	1≤In≤100	1,2,3	7500	/	4000	3000,U1 6000,C1	10000	7500	/	/
		100<In≤400	2,3,4	/	/	7500	4000,U1 6000,C1	/	/	/	/
		100≤In≤350	2,3,4	/	7500	/	/	/	/	7500	/
	DC125	1≤In≤100	1,2	5000	/	/	3000,U1 6000,C1	/	/	/	/
	DC125	100≤In≤400	2, 3, 4	/	/	/	4000,U1 6000,C1	/	/	/	/
	AC120	1≤In≤70	1	/	/	/	/	5000	/	/	/
	AC240	1≤In≤20	1,2,3	/	/	/	/	5000	/	/	/
	AC120/240	1≤In≤70	2,3	/	/	/	/	5000	/	/	/
	AC125/250	1~100	2	/	/	/	5000,C1	/	/	/	/
	AC230/240	1~100	1	5000	/	/	/	/	5000	/	/
	AC250	1~100	1	/	/	/	5000,C1 4000,U1	/	/	/	/
	AC400/415	1~100	2,3	5000	/	/	/	/	5000	/	/
	AC480Y/277	1~100	3	/	/	/	5000,C1	/	/	/	/

File number	NDT500044	Version	The 3 th version	Date	20181030
-------------	-----------	---------	-----------------------------	------	----------

AC220	32,35,40,45,50	1,2	/	/	/	/	/	/	/	3000
	60,70,80,90,100	2	/	/	/	/	/	/	/	3000
AC380	32,35,40,45,50, 60,70,80,90,100	3	/	/	/	/	/	/	/	3000

3.8 Working conditions

3.8.1 Altitude: ≤2000m

3.8.2 Operation temperature: -40℃~+85℃

3.8.3 Humidity: ≤95%

3.8.4 Service place without explosive media, gas and dust which are corrosive and conductive.

3.8.5 Be mounted free from rain and snow.

4 Tripping characteristic

4.1 Tripping timetable (in seconds)

Current Curve	In	1.25 In	2 In	6 In	10 In
Z2	No trip	0.5-6.5	0.13-1.2	0.008-0.12	0.004-0.06
Z4	No trip	2-60	0.6-20	0.011-1.3	0.004-0.1
Z6	No trip	45-345	9-60	0.15-5.8	0.005-1.7
J2	No trip	0.7-12	0.13-1.3	0.008-0.13	0.004-0.055
J4	No trip	10-160	2.2-20	0.02-1.3	0.005-0.065
J6	No trip	50-700	10-90	0.1-7	0.006-2

4.2 Tripping curves

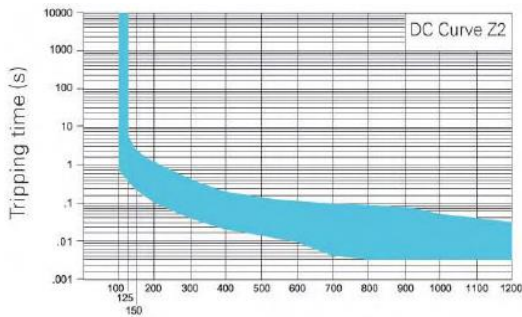

Rated current percentage

Z2 Curve

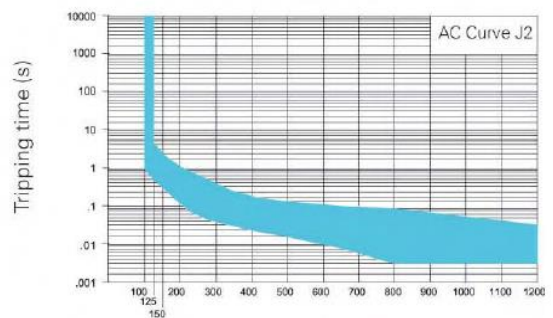

Rated current percentage

J2 Curve

File number	NDT500044	Version	The 3 th version	Date	20181030
-------------	-----------	---------	-----------------------------	------	----------

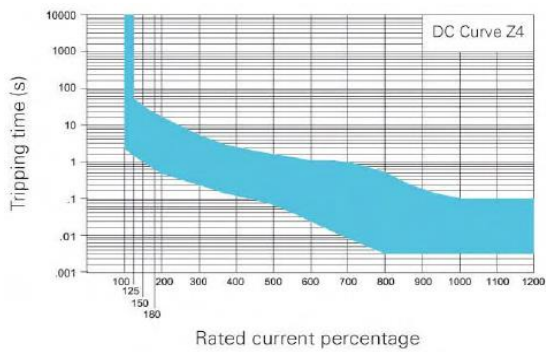

Z4 Curve

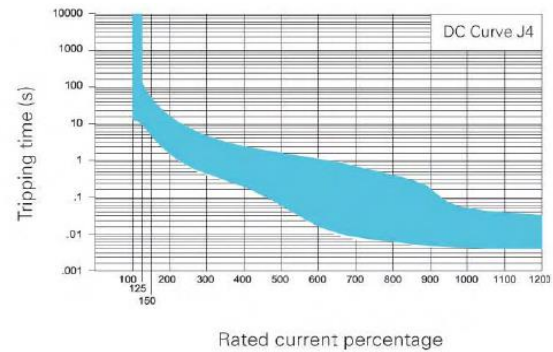

J4 Curve

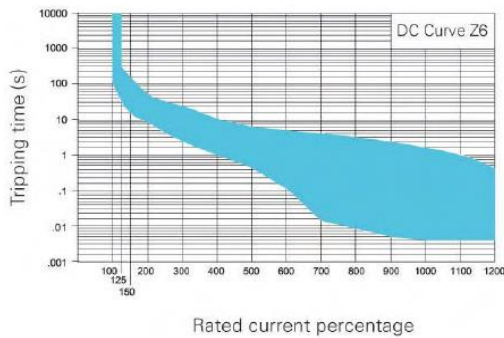

Z6 curve

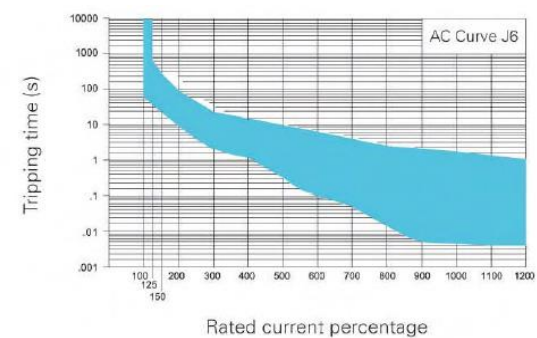

J6 curve

5 Dimensions and wiring method

5.1 Outline dimensions

5.1.1 Actuator code S*, actuator number A, all wiring methods available. (Also suitable for HI-Inrush product and mid trip product.)

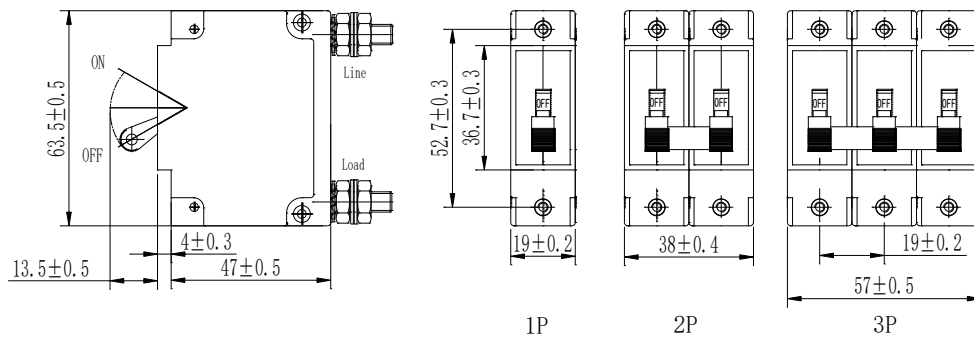

5.1.2 Actuator code Y1-Y4/Y7-Y8, single-pole product with actuator number A and all wiring methods available, multi-pole product with actuator number B and wiring method U/V/L/B/N/W/K available. (Also suitable for HI-Inrush product.)

File number	NDT500044	Version	The 3 th version	Date	20181030
-------------	-----------	---------	-----------------------------	------	----------

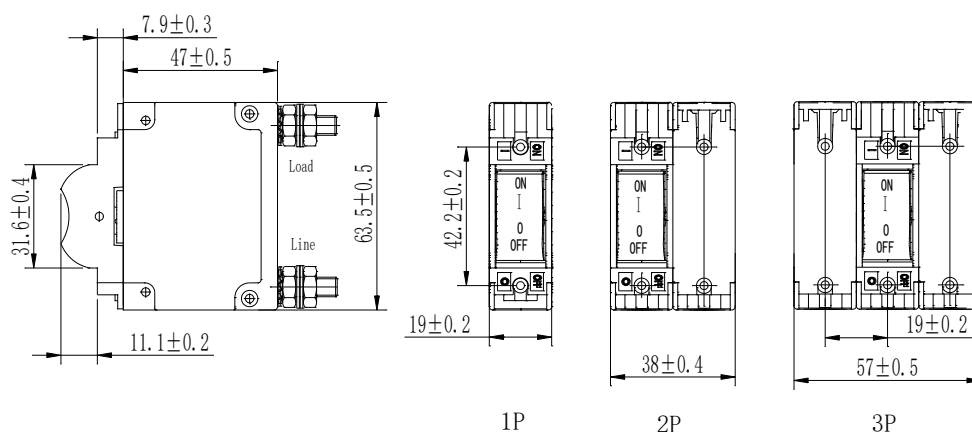

5.1.3 Actuator code Y5-Y6, single-pole product with actuator number A and all wiring methods available, multi-pole product with actuator number B and wiring method U/V/L/B/N/W/K available. (Also suitable for HI-Inrush product.)

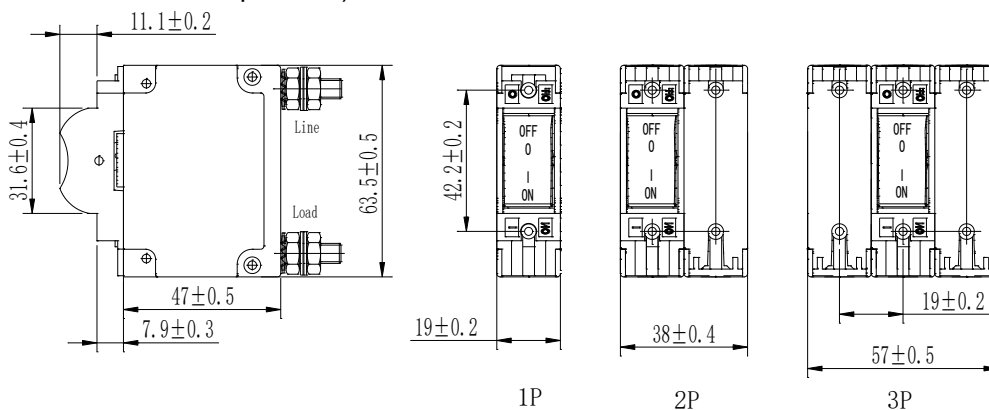

5.1.4 Actuator code A, single-pole product with actuator number A and all wiring methods available, multi-pole product with actuator number B and wiring method U/V/L/B/N/W/K available. (Also suitable for HI-Inrush product.)

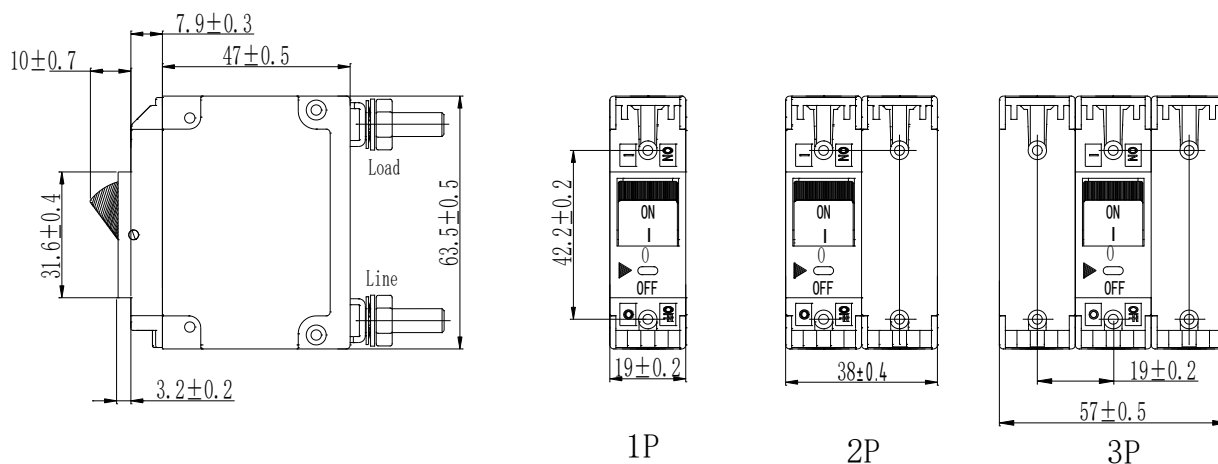

5.1.5 Actuator code S*/L*, single-pole product with actuator number A and multi-pole product with actuator number B, wiring method U/V/L/B/N/W/K available. (Also suitable for HI-Inrush product.)

File number	NDT500044	Version	The 3 th version	Date	20181030
-------------	-----------	---------	-----------------------------	------	----------

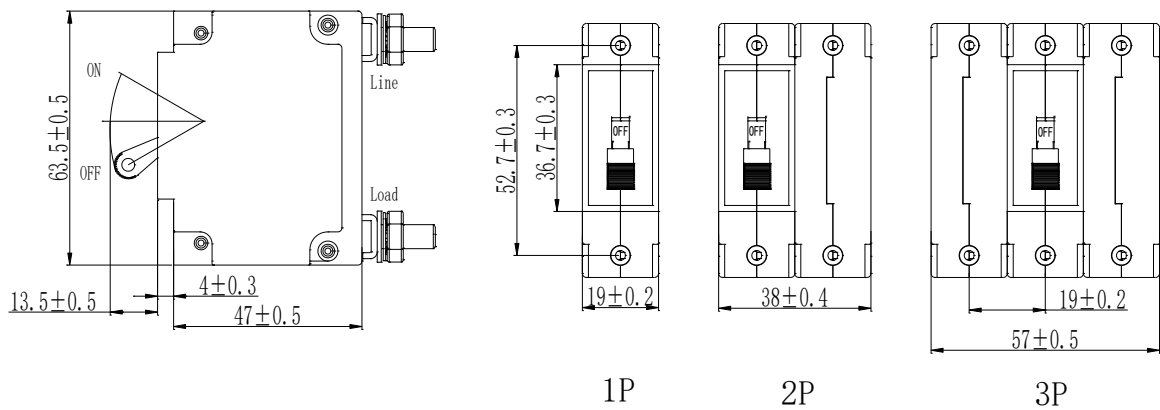

5.1.6 Actuator code S*/L*, actuator number A, wiring method U/V/L/B/NW/K available. (Also suitable for HI-Inrush product and mid trip product.)

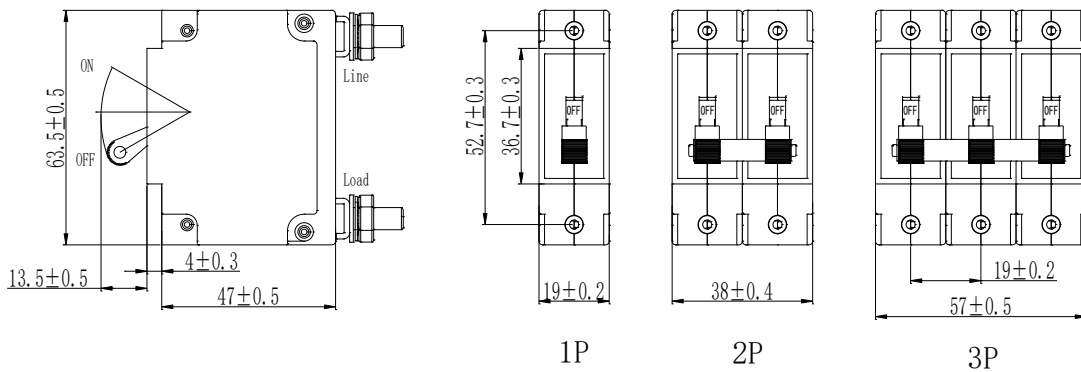

5.1.7 Parallel connected product, actuator code L*, actuator number A, wiring method S/U/H/N available.

a. Wiring separately (Actuator code L* is also suitable for parallel connected single-coil product.)

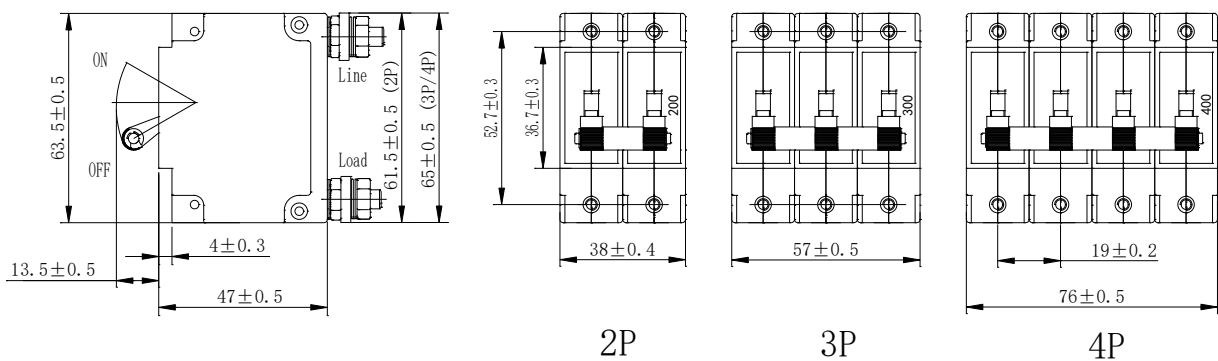

b. Wiring with connection bar (Actuator code L* is also suitable for 3P parallel connected single-coil product.)

File number	NDT500044	Version	The 3 th version	Date	20181030
-------------	-----------	---------	-----------------------------	------	----------

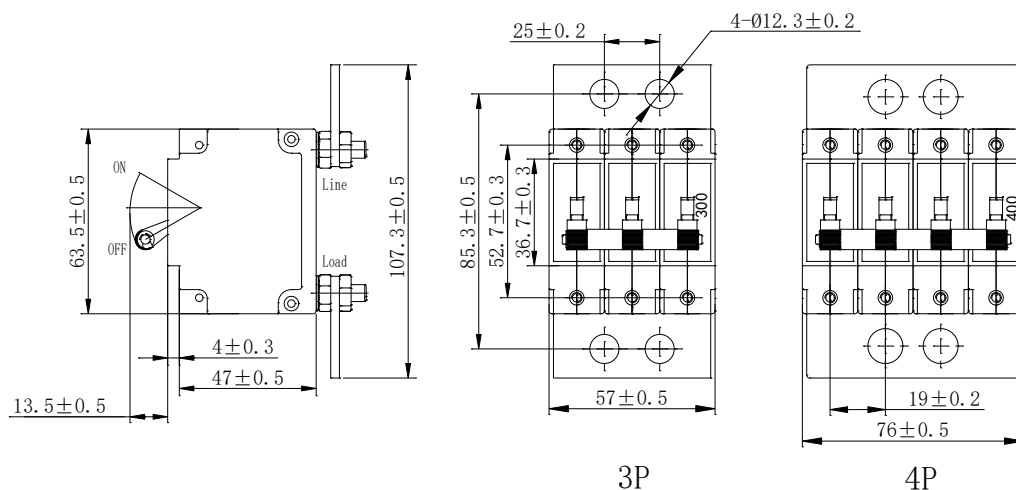

5.1.8 Parallel connected product, actuator code L*, actuator number B, wiring method U/N available.

a. Wiring separately (Actuator code L* is also suitable for parallel connected single-coil product.)

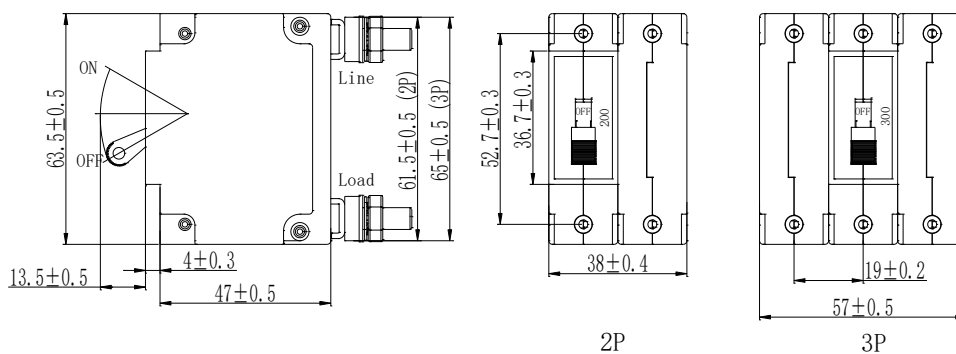

b. Wiring with connection bar (Actuator code L* is also suitable for parallel connected single-coil product.)

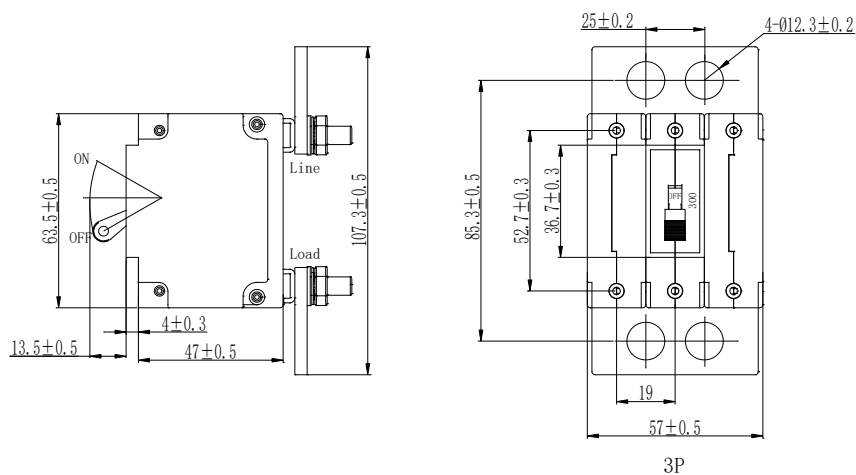

5.1.9 Parallel connected product, actuator code A*/Y*, actuator number B, wiring method U/N available.

a. Wiring separately (Also suitable for parallel connected single-coil product)

File number	NDT500044	Version	The 3 th version	Date	20181030
-------------	-----------	---------	-----------------------------	------	----------

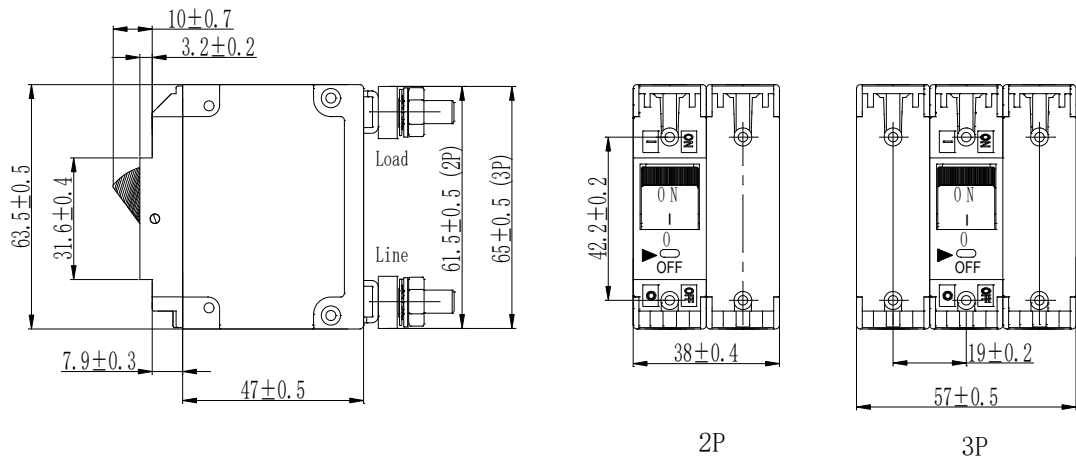

b. Wiring with connection bar (Also suitable for parallel connected single-coil product)

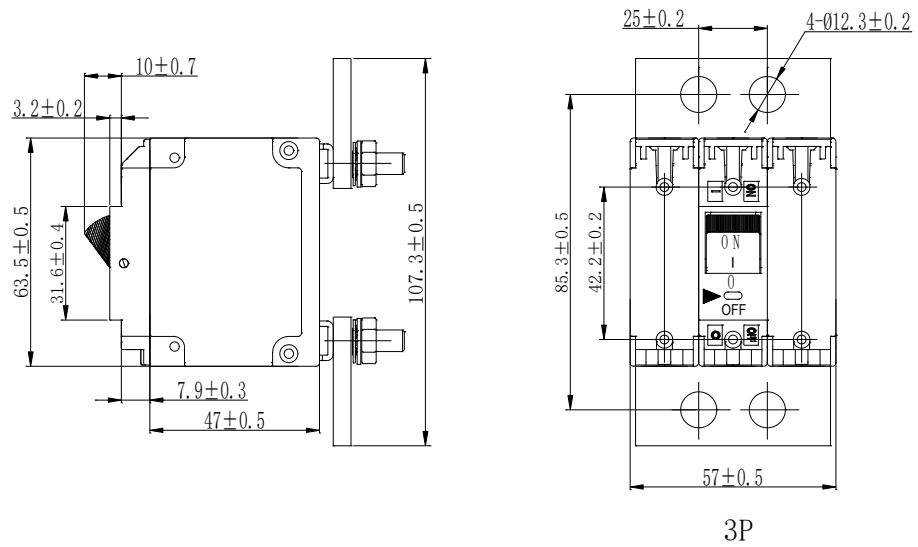

5.1.10 UL489 product, actuator code S*/L*, actuator number A, all wiring method available; actuator number B, wiring method U/B/L/N/K available.

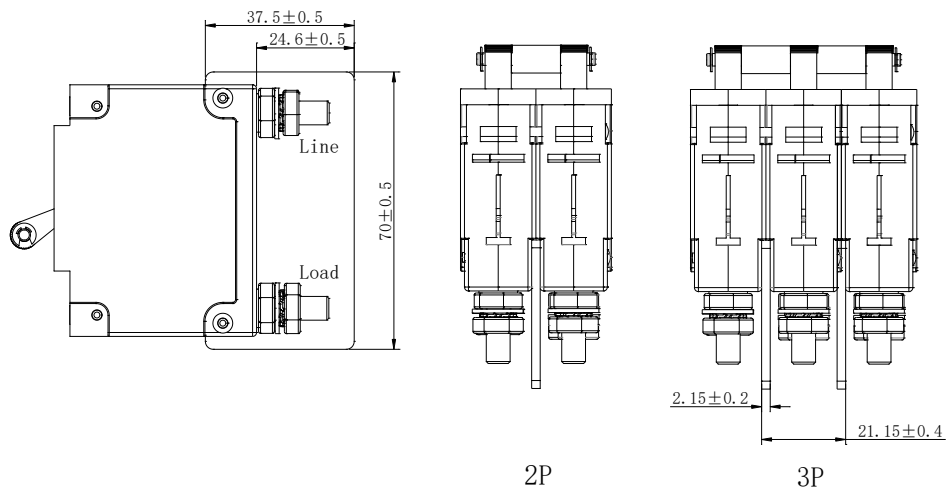

File number	NDT500044	Version	The 3 th version	Date	20181030
-------------	-----------	---------	-----------------------------	------	----------

5.2 Terminal dimensions

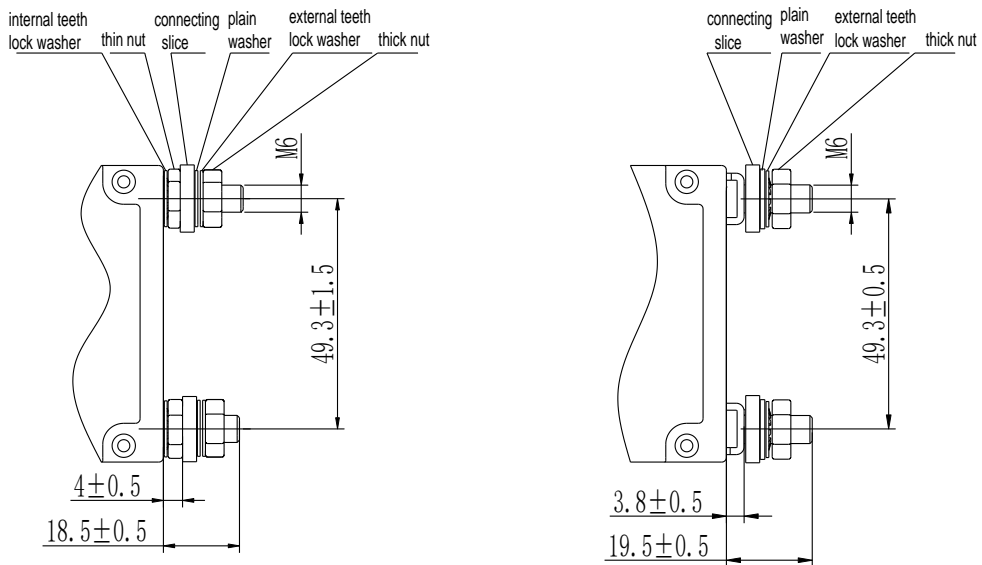
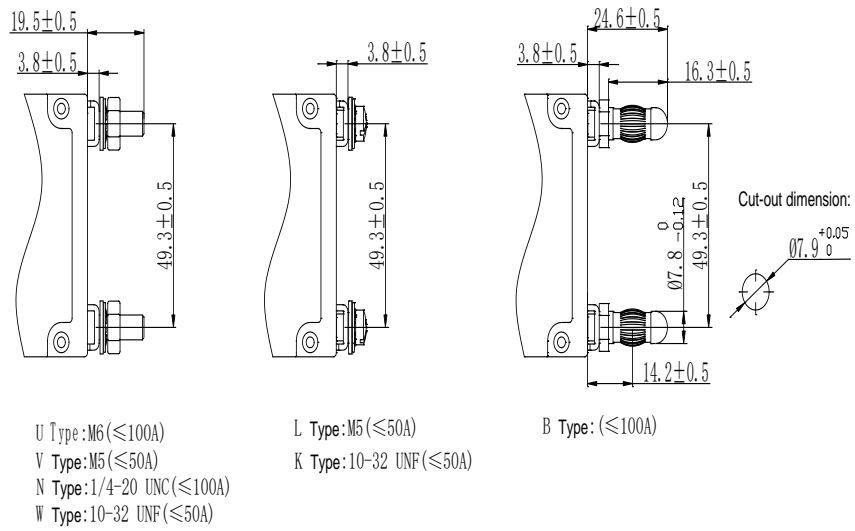
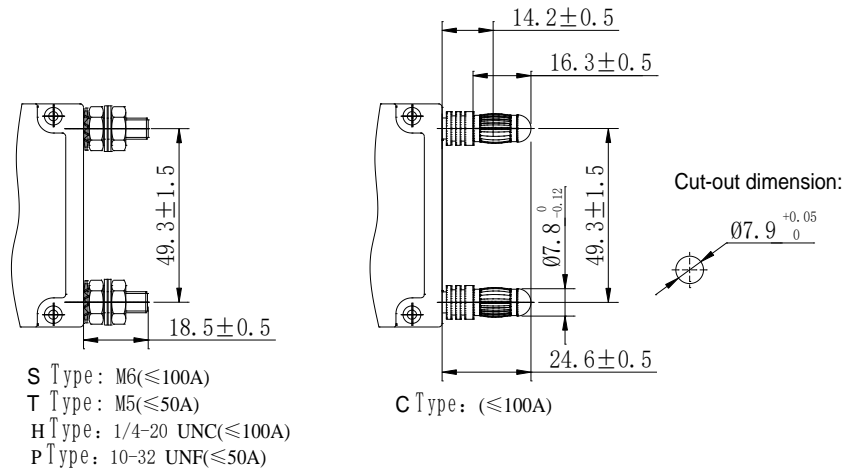

Parallel breaker with H/S type wiring method

Parallel breaker with U/N type wiring method

File number	NDT500044	Version	The 3 th version	Date	20181030
-------------	-----------	---------	-----------------------------	------	----------

Note: Applied torque on each type screw is shown in following table:

Diameter of screw (mm)	Applied torque (N.m)
M3 (6-32UNC) screw	0.5
M6 (1/4-20) stud	3.0
M5(10-32) stud	2.0
M5 (10-32UNF) screw	2.0
Paralleled F type, M6(1/4-20) stud	5.0

5.3 Installation dimensions

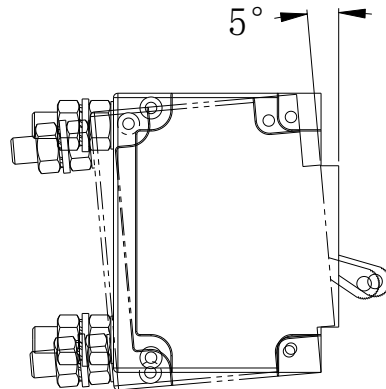
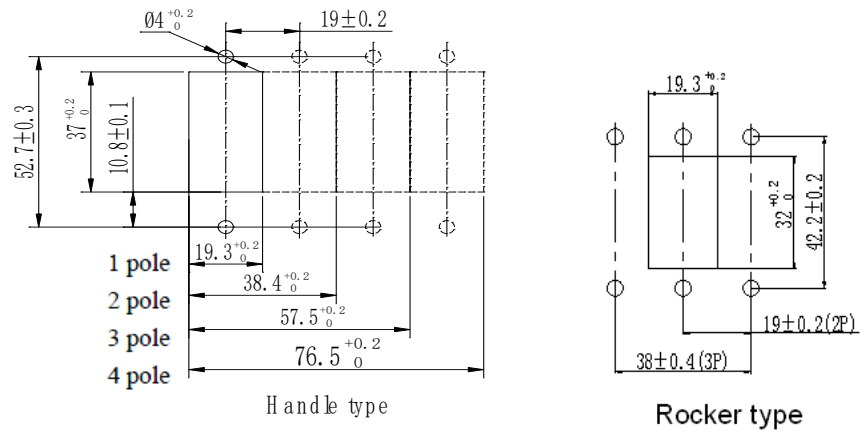

Note: The breaker should be mounted within 5° of the mounting plane in case the characters of the product are affected.

File number	NDT500044	Version	The 3 th version	Date	20181030
-------------	-----------	---------	-----------------------------	------	----------

6 Circuit diagrams

6.1 Circuit diagram for product w/ aux. contact

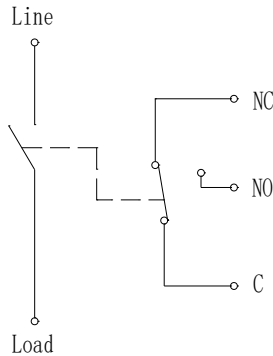

Handle Position VS. Aux. Contact Mode		
Breaker Mode	Handle Position	Aux. Contact Mode
OFF		
ON		
Electrical Trip		

7 Packing and depositing

7.1 Maximum packing quantity

7.1.2 For standard product

- 1-pole: 30 pieces in a box, 3 boxes in an overwrap carton.
- 2-pole: 15 pieces in a box, 3 boxes in an overwrap carton.
- 3-pole: 10 pieces in a box, 3 boxes in an overwrap carton.

7.1.3 For multi-pole paralleled product

- 2-pole: 6 pieces in a box, 3 boxes in an overwrap carton.
- 3-pole wiring separately: 4 pieces in a box, 3 boxes in an overwrap carton.
- 3-pole wiring with connection bar: 3 pieces in a box, 3 boxes in an overwrap carton.
- 4-pole: 3 pieces in a box, 3 boxes in an overwrap carton.

7.1.3 For Korea KC approved product

- 1-pole: 28 pieces in a box, 3 boxes in an overwrap carton.
- 2-pole: 14 pieces in a box, 3 boxes in an overwrap carton.
- 3-pole: 9 pieces in a box, 3 boxes in an overwrap carton.

7.2 The products should be stored in the warehouse where there is ventilation. The relative humidity there should not exceed 80%, and the ambient temperature there is between -25°C to +60°C. In addition, there should not be acidic, alkaline and corrosive gas in the air. The products should not be deposited more than 3 years in the above mentioned conditions since the producing date.

File number	NDT500044	Version	The 3 th version	Date	20181030
-------------	-----------	---------	-----------------------------	------	----------

8 Accessories

8.1 Auxiliary contact

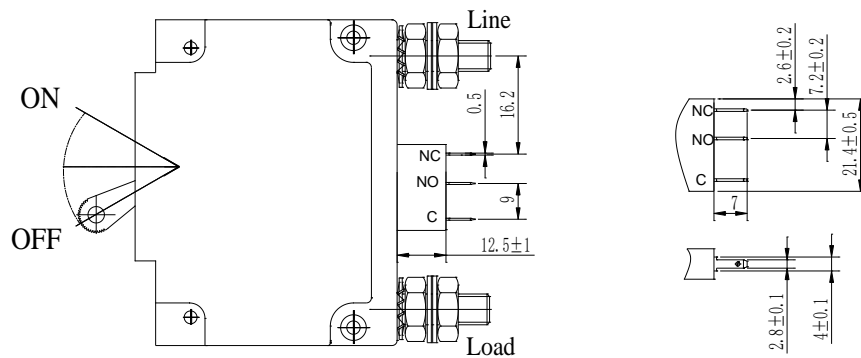

8.2 Optional parts (NM1 Panel)

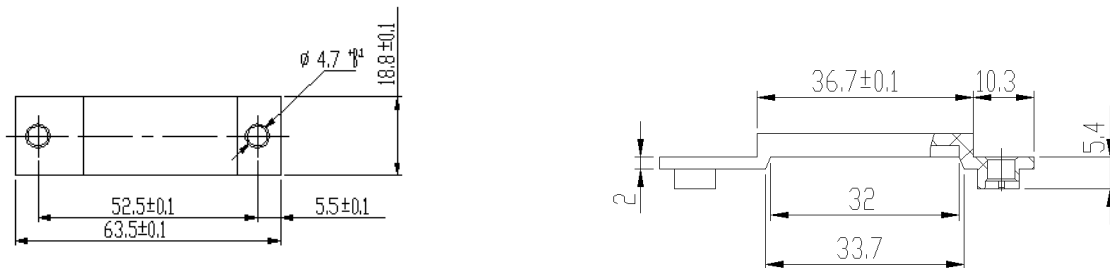

Note: Optional parts will be packed separately.

9 Notices

- 9.1 Manufacturer will take no responsibility for problems caused by disassembly privately.
- 9.2 Attention to live part when the breaker is energized and avoid touching them.
- 9.3 Please make sure reliable connection to avoid fault tripping or damage of terminal caused by exceptional heat resulting from unsuitable connection.
- 9.4 Please maintain the distance of 70mm min. from the arc jet slot of the product (LINE side) during installation in case there is short circuit breaker due to arc jet.
- 9.5 The inclination angle between the product's installation surface and vertical installation surface should not exceed 5degree.
- 9.6 For actuator type S*/L*, switching force should be $\leq 10\text{N}$ for single-pole, $\leq 15\text{N}$ for two-pole, $\leq 30\text{N}$ for three-pole.
- 9.7 For screw mounting type breaker, applied torque on $\text{M3} \times 5$ or 6-32UNC screw is 0.5N.m
- 9.8 When manual operating breaker with actuator number B, the force should be applied in middle handle position. And the time between ON and OFF operation should be more than 1s.
- 9.9 The actual contact position of the breaker has to be observed from the actuator's position or the auxiliary contact which is connected to breaker in series.

File number	NDT500044	Version	The 3 th version	Date	20181030
-------------	-----------	---------	-----------------------------	------	----------