

Product Specifications

Product name: Molded Case Circuit Breaker (MCCB)

Product model: NDM3-100

Date: 20180319

Prepared by	Reviewed by	Approved by
Li Yang	Xie Wwi	Sun Conglin

Document No.	NDT2930395	Version	0	Implementation date	20180319
--------------	------------	---------	---	---------------------	----------

1. Applicable Scope and Purpose

NDM3-100 molded case products apply to infrequent switching of circuits with the AC 50Hz/60 Hz, the rated working voltage of 690V and rated working current of 100A as well as infrequent motor starting. With the overload, short circuit and undervoltage protection functions, the circuit breaker can protect lines and power equipment from damage.

2. Picture of the Product



3. Specification and Model Description

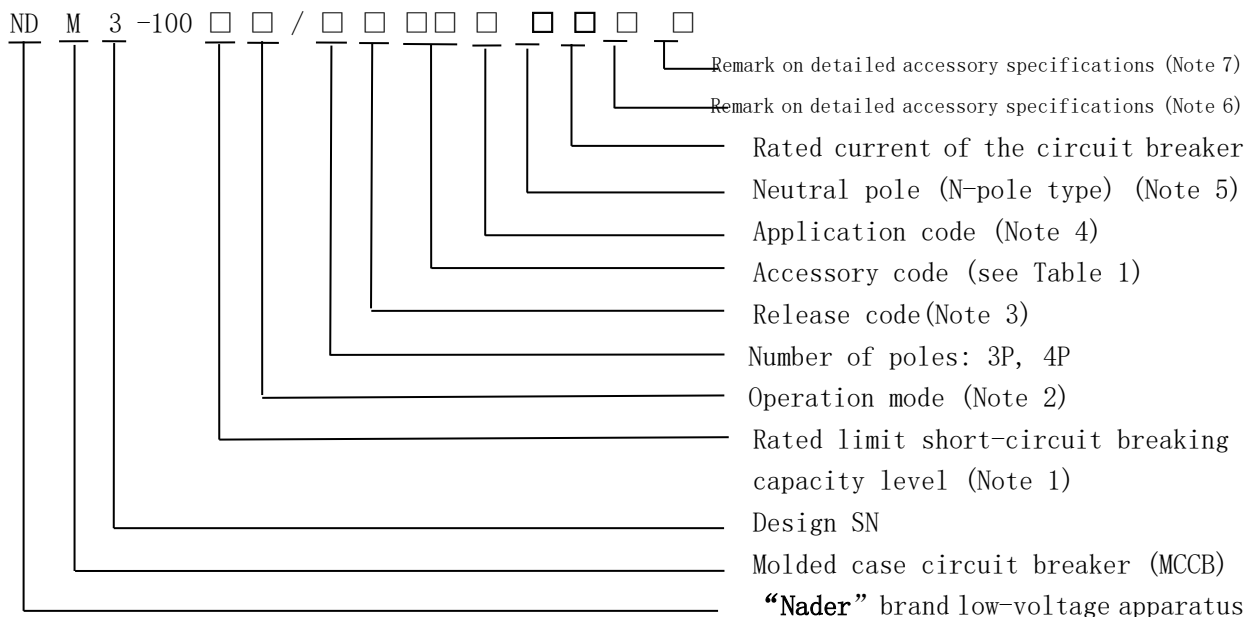

Document No.	NDT2930395	Version	0	Implementation date	20180319
--------------	------------	---------	---	---------------------	----------

Note 1: Rated limit short-circuit breaking capacity of 3P products:

L: Standard type, M: Relatively high breaking type,

Note 2: Operation mode:

No code is available for the direct handle-operated mode

P: Motor-operated

Z: Rotation handle;

Note 3: Release code:

0: Tripper (none)

2: Instantaneous tripper only

3: Complex tripper;

Note 4: Application code

No code is available for the circuit breaker for distribution

2: Protection motor type;

Note 5: Type A: The N-pole isn't installed with an overcurrent tripper, but always connected;

Type B: The N-pole isn't installed with an overcurrent tripper, but on-off with the other three poles;

Type C: The N-pole is installed with an overcurrent tripper, and on-off with the other three poles;

Note 6: DL: Dedicated for Electric Power;

For all power products, a label marked with "Dedicated for Electric Power" shall be affixed on the front face of the products.

Note 7: Remark on detailed accessory specifications

Detailed description of connection-type or rotation handle:

Normal products are uncoded;

P: Extended connection busbar;

JK: Only the inlet wire end adopts the connection frame while the outlet wire end adopts the front-plate connection mode as the wiring mode;

CK: Only the outlet wire end adopts the connection frame while the inlet wire end adopts the front-plate connection mode as the wiring mode;

K: Inlet and outlet wire ends adopt the connection frame as the wiring mode;

H: Rear-plate connection

Z1: Plug-in rear-plate connection

Z2: Plug-in front-plate connection

For example: NDM3-100M/3300 63A (plug-in rear-plate connection);

NDM3-100Z/3321 63A (CS1-A);

NDM3-100/33002 63A (connection busbar), etc.

2. Indicate the accessory voltage; the voltage of the electric operating mechanism, undervoltage tripper and shunt tripper shall be indicated temporarily:

① The voltage of the electric operating mechanism is represented as CD2 space+ voltage: For example NDM3-100P/3020 63A (CD2 DC24V),

② If only the voltage exists in the (), the voltage of the shunt tripper or undervoltage tripper from the accessories is indicated in default,

Document No.	NDT2930395	Version	0	Implementation date	20180319
--------------	------------	---------	---	---------------------	----------

For example: NDM3-125L/3341 125A (AC220V)

Table 1: Comparison Table of Accessory Code:

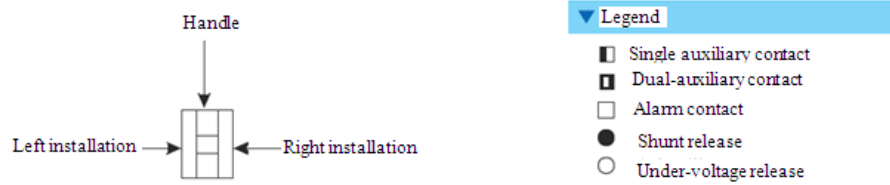

Document No.	NDT2930395	Version	0	Implementation date	20180319
--------------	------------	---------	---	---------------------	----------

附件代号	附件名称	型号	极数
00	无	NDM3-100	3
10	分励脱扣器		
20	双辅助触头		
21	单辅助触头		
30	欠电压脱扣器		
40	分励脱扣器 双辅助触头		
41	分励脱扣器 单辅助触头		
50	分励脱扣器 欠电压脱扣器		
60	二组双辅助触头		
61	二组单辅助触头		
62	双辅助触头 单辅助触头		
70	欠电压脱扣器 双辅助触头		
71	欠电压脱扣器 单辅助触头		
08	报警触头		
18	分励脱扣器 报警触头		
28	双辅助触头 报警触头		
38	欠电压脱扣器 报警触头		
48	分励脱扣器、辅报触头		
58	辅报触头		
68	双辅助触头、辅报触头		
78	欠电压脱扣器、辅报触头		

附件代号	Accessory code
附件名称	Accessory name
安装位置	Installation position
极数	Number of poles
型号	Model
无	None
分励脱扣器	Shunt release
双辅助触头	Dual-auxiliary contact

Document No.	NDT2930395	Version	0	Implementation date	20180319
--------------	------------	---------	---	---------------------	----------

单辅助触头	Single auxiliary contact
欠电压脱扣器	Under-voltage release
分励脱扣器双辅助触头	Shunt release, dual-auxiliary contact
分励脱扣器单辅助触头	Shunt release, single auxiliary contact
分励脱扣器欠电压脱扣器	Shunt release, under-voltage release
二组双辅助触头	Two sets of dual auxiliary contacts
二组单辅助触头	Two sets of single auxiliary contacts
双辅助触头 单辅助触头	Dual-auxiliary contact, single auxiliary contact
欠电压脱扣器 双辅助触头	Under-voltage release, dual-auxiliary contact
欠电压脱扣器 单辅助触头	Under-voltage release, single auxiliary contact
报警触头	Alarm contact
分励脱扣器 报警触头	Shunt release, alarm contact
双辅助触头 报警触头	Dual-auxiliary contact, alarm contact
欠电压脱扣器 报警触头	Under-voltage release, alarm contact
分励脱扣器单辅助/报警触头	Shunt release, single auxiliary/alarm contact
单辅助/报警触头	Single auxiliary/alarm contact
双辅助触头 单辅助/报警触头	Dual-auxiliary contact, single auxiliary/alarm contact
欠电压脱扣器 单辅助/报警触头	Under-voltage release, single auxiliary/alarm contact

4. Main Technical Parameters

Model		NDM3-100	
Rated current of housing I_{nm} (A)		100	
Rated current I_n (A)		10, 16, 20, 25, 32, 40, 50, 63, 80, 100	
Rated insulation voltage U_i (AC V)		1000	
Rated impulse withstand voltage U_{imp} (V)		8000	
Number of poles		3	4
Rated limit short-circuit breaking capacity level		C	/
Rated limit short-circuit breaking capacity I_{cu} (kA)	AC380/400/41 5V	40	40
	AC500V	15	15
	AC660/690V	12	12
Rated operating short-circuit breaking capacity	AC380/400/41 5V	30	30
	AC500V	12	12

Document No.	NDT2930395	Version	0	Implementation date	20180319
--------------	------------	---------	---	---------------------	----------

Ics (kA)	AC660/690V	10	10
Operating performance	POWER ON	8000	
	Without electricity	20,000	

4.1 Connection capacity

Rated current A	10	16, 20	25	32	40, 50	63	80	100
Wire cross-section area mm ²	1.5	2.5	4	6	10	16	25	35

4.2 Tightening torque value of terminal/mounting screw

SN	Rated current of frame	Thread diameter	Torque value
1	NDM3-100	M8	12
		M3	1

Document No.	NDT2930395	Version	0	Implementation date	20180319
--------------	------------	---------	---	---------------------	----------

4.3 Derating factor table of the circuit breaker

SN	Housing	Derating Factor Table of Product Temperature							
		Temperature	40°C	45°C	50°C	55°C	60°C	65°C	70°C
1	100	Derating factor	1	0.977	0.954	0.931	0.907	0.883	0.858

Note: 1). When the operating ambient temperature is below 40°C, the product can be used normally without derating capacity.

2). The above derating factors are measured at the frame current.

4.4 High-altitude derating factor

High-altitude Derating Factor Table of Molded Case Circuit Breaker

Altitude (km)	Rated operating current	Maximum operating voltage	Rated power frequency withstand voltage
2	In	Ue	U
2.5	In	Ue	U
3	0.98In	0.83Ue	0.89U
3.5	0.97In	0.77Ue	0.85U
4	0.96In	0.71Ue	0.80U
4.5	0.95In	0.67Ue	0.77U
5	0.94In	0.63Ue	0.73U

5. Normal Working Environment

- 1) Altitude ≤ 2000 m;
- 2) Ambient temperature: -35°C ~ + 70°C; the average within 24h shall not be more than +35°C. If the ambient temperature is higher than +40°C, the user needs to reduce the capacity. See "Derating Factor Table of Product Temperature Change" for the derating factory;
- 3) The relative humidity at an ambient temperature of +40°C should not exceed 50%. A higher relative humidity is allowed at a lower temperature. For example, the relative humidity at 20°C can reach 90%
- 4) For frost due to temperature change, the corresponding measures should be taken
- 5) The product can withstand the effects of wet air, salt mist and oil mist.
- 6) The installation category of the circuit breaker connected/not connected to the main loop is III and II respectively
- 7) The pollution level is Level 3
- 8) The maximum gradient is 22.5°.
- 9) The product can be disposed in places that are free from explosive media, media corrosive to metal, insulation damaging gas, and conductive dust
- 10) The product should be installed free from snow and rain

Document No.	NDT2930395	Version	0	Implementation date	20180319
--------------	------------	---------	---	---------------------	----------

11) In case of stricter user conditions than the above description, negotiate with the manufacturer

6. Tripping Characteristics

NDM3-100 Time/Current Characteristic Curve

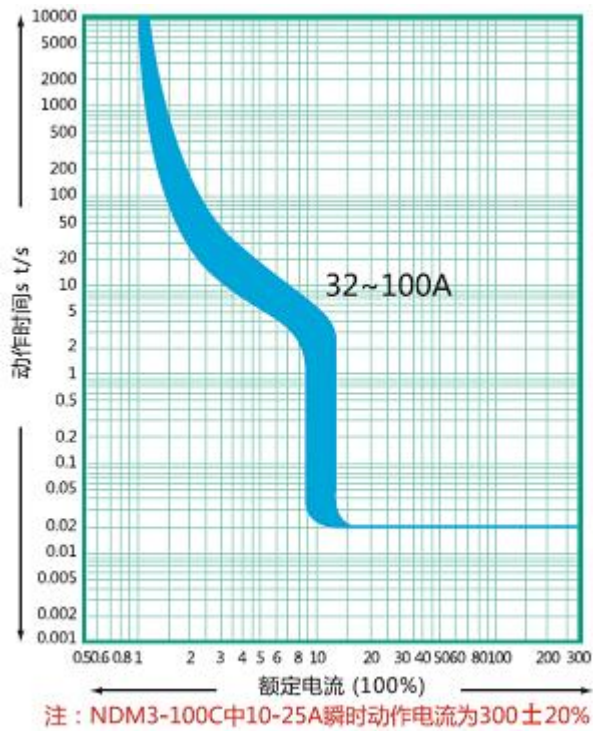

Document No.	NDT2930395	Version	0	Implementation date	20180319
--------------	------------	---------	---	---------------------	----------

7. Outline and Installation Dimensions

Under-voltage release

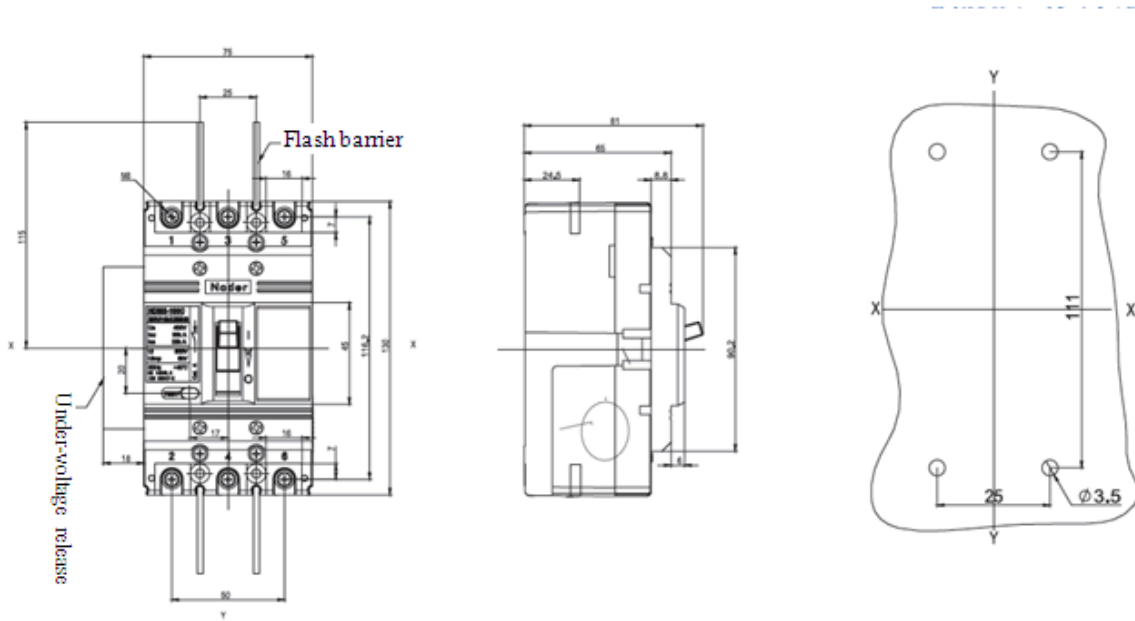

Note: The limit deviation not indicated with the tolerance dimensions is as per GB/T 1804-m.

7.1 Mounting distance (mm)

1) Insulation distance mounted in the metal cabinet (unit: mm), as shown below:

Mounting distance	A (inlet wire end to the cabinet face)		B (distance from side to cabinet)	C (outlet wire end to the cabinet face)
	With a 0 arcing cover	Without a 0 arcing cover		
NDM3-100	25	65	30	30

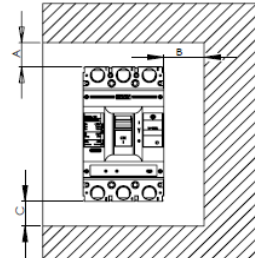

2) Minimum center distance between rowed circuit breakers:

Specification	Width of circuit breaker (mm)	Center distance (mm)
		3P
NDM3-100	75	105

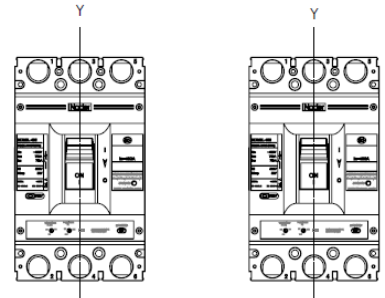

Note: Check the connected busbar or cable during rowing or stacking to ensure that the air insulation distance won't be reduced.

Document No.	NDT2930395	Version	0	Implementation date	20180319
--------------	------------	---------	---	---------------------	----------

3) Minimum center distance between stacked circuit breakers

Specification	H (distance of circuit breaker from bottom)	
	With a 0 arcing cover	Without a 0 arcing cover
NDM3-100	90	90

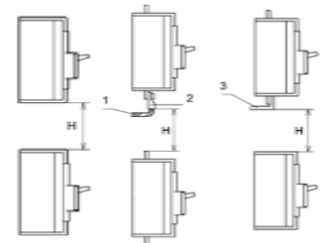

8. Installation Mode

For vertical installation of the product, the gradient between the installation surface and the vertical plane is no more than $\pm 22.5^\circ$.

Horizontal installation of the product.

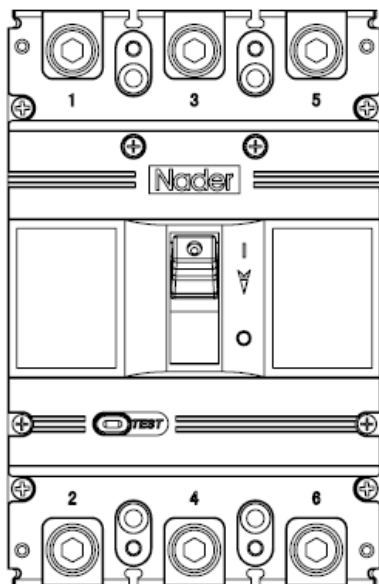

Vertical Installation

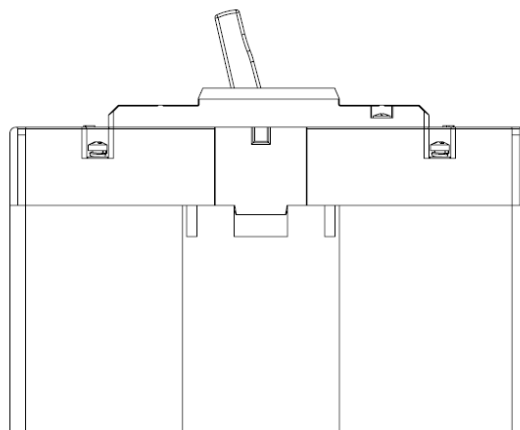

Horizontal Installation

9. Packaging and Storage

Minimum packaging quantity: 1 piece/box. The packaged products should be stored in a warehouse with the ambient temperature of $-40^\circ\text{C} \sim 75^\circ\text{C}$ and relative humidity below 80% without acidic, alkali or other corrosive gas in the surrounding air. Under the conditions above, the storage period shall be no more than 36 months since the manufacturing date.

Document No.	NDT2930395	Version	0	Implementation date	20180319
--------------	------------	---------	---	---------------------	----------

10. List of Accessories and Installation

SN	Name	Specification	Quantity/Set(3P)	Quantity/Set(4P)
1	Cross small pan-head combination screws	M3X70	4	6
2	Hexagon nut	M3	4	6
3	Phase partition	—	4	6

11. Precautions

▲ Various characteristics and accessories of the circuit breaker are set in the factory, which shall not be adjusted randomly;

▲ The circuit breaker handle can be located in three positions, indicating three states: on, off and free tripping. When the handle is in the free tripping position, pull the handle in the off direction when the circuit breaker is connected and on.